

FAG



Radial Insert Ball Bearings and Housing Units

Black Series

SCHAEFFLER



Foreword

FAG Black Series

The new radial insert ball bearing and housing units FAG Black Series from Schaeffler give easy mounting, smooth running and high reliability and thus allow particularly economical bearing arrangements.

The dimensions of the FAG housings, made from flake graphite cast iron and with a primer paint coating, conform to JIS B 1559. These single piece cast housings can support moderate to high radial and axial loads. The radial insert ball bearings have basic protection against corrosion due to the Durotect[®]B coating.

The bearing units are particularly suitable for applications with moderate to high loads.

Typical areas of application are:

- agricultural, construction and mining machinery
- power transmission and conveying equipment
- pumps
- textile, paper and woodworking machinery
- machines for the food container filling, wood and packaging industry
- steel industry.

Radial insert ball bearings

FAG radial insert ball bearings with a spherical outer ring are based on deep groove ball bearings 62 and are designed in accordance with JIS B 1558. The outer and inner rings as well as the flinger shields of the radial insert ball bearings are provided with the Durotect[®]B coating in order to offer basic protection against corrosion. The Black Series radial insert ball bearings are available with two location methods and one type of seal. They can be relubricated and are particularly easy to install.

Housing units with flake graphite cast iron housings

Housing units in accordance with JIS B 1557 comprise FAG flake graphite cast iron housings with a concave bore in which FAG radial insert ball bearings are fitted. These units are matched to each other and are available as plummer block housing units, flanged housing units and take-up housing units.

Radial insert ball bearings with a spherical outer ring, when fitted in housings with a concave bore, can compensate for static misalignment of the shaft.

Housing units are supplied with a loose packed lubrication nipple and integrated end cap for the lubrication nipple as well as an Allen key.

Contents

	Page
Radial insert ball bearings.....	4
Housing units	18

FAG



Radial insert ball bearings

Radial insert ball bearings

	Page
Product overview	Radial insert ball bearings..... 6
Features	Anti-corrosion protection 7
	Location on shaft 7
	Sealing 8
Design and safety guidelines	Compensation of static misalignments 9
	Axial load carrying capacity of location method 9
	Speed limits for radial insert ball bearings..... 10
	Shaft tolerances for radial insert ball bearings..... 11
Accuracy	Standard tolerances of radial insert ball bearings 11
	Radial internal clearance of radial insert ball bearings 12
Dimension tables	Radial insert ball bearings with grub screws in inner ring, spherical outer ring 14
	Radial insert ball bearings with adapter sleeve, spherical outer ring 16

Product overview Radial insert ball bearings

**With grub screws
in inner ring**

Spherical outer ring



With adapter sleeve

Spherical outer ring



Radial insert ball bearings

Features These radial insert ball bearings are based on single row deep groove ball bearings 62 and comprise a solid section outer ring and an inner ring extended on both sides.

The bearings have plastic cages and are sealed on both sides by single piece seals RSR with a vulcanised seal lip and an outer flinger shield.

The honed raceways of the bearing rings, in conjunction with the high ball grade, ensure quiet running and a reduced frictional torque.

The outer ring has a spherical outside surface. In combination with a housing matched to the design, bearings with a spherical outer ring can compensate static misalignments of the shaft, see page 9.

The radial insert ball bearings are pregreased and can be relubricated. For this purpose, they have one lubrication hole in the outer ring. In addition, a ball (anti-rotation ball) offset by 90° is fitted as a retainer and prevents undesirable rotation of the outer ring in the housing cavity if high circumferential forces are present.

Inch size designs The radial insert ball bearings are also available with inch size bore dimensions, see dimension table.

Anti-corrosion protection The inner and outer rings as well as the flinger shields of the radial insert ball bearings are provided with the Durotect®B coating in order to offer basic protection against corrosion. Adapter sleeves have a Durotect®B or phosphate coating.

Location on shaft Radial insert ball bearings are particularly easy to fit and are suitable for drawn shafts with the tolerances h6 to h9.

In the radial insert ball bearings UC, the inner ring is located on the shaft by means of two grub screws offset by 120°, *Figure 1*, page 8. They are suitable for bearing arrangements with a constant direction of rotation or, under low speed and load, for an alternating direction of rotation.

The grub screws are self-retaining and have a fine pitch thread with cup point for secure location of the bearings. In order to allow better differentiation, the metric grub screws have a Durotect®B coating while the inch size grub screws are zinc plated.

In the radial insert ball bearings UK, the inner ring is located on the shaft by means of a concentric adapter sleeve, *Figure 2*, page 8. They are suitable for bearing arrangements with an alternating direction of rotation, even under high speed and load.

Radial insert ball bearings

UC

Figure 1
Location by grub screws
in the inner ring

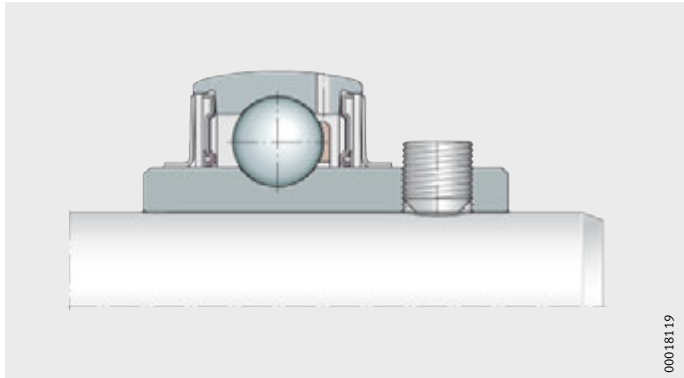

00018119

UK

Figure 2
Location by adapter sleeve

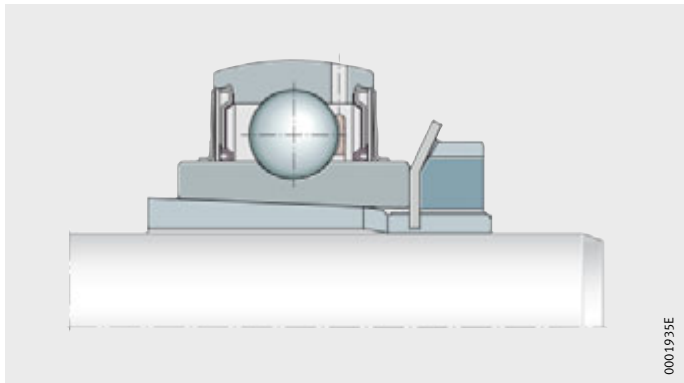

0001935E

Tightening torques

Tightening torques for metric and inch size grub screws, see table, page 29.
Tightening torques for locknuts, see table, page 29.

Sealing

FAG Black Series radial insert ball bearings are supplied with seals RSR, see table.

Seal types

Seal RSR	
<p>A detailed cross-sectional diagram of a seal RSR installed in a bearing housing. The seal consists of a zinc-plated sheet steel washer with a vulcanised and radially preloaded seal lip made from NBR and an additional flinger shield.</p>	<p>0001811A</p> <p>Single piece, zinc-plated sheet steel washer with vulcanised and radially preloaded seal lip made from NBR and additional flinger shield</p>

Design and safety guidelines
Compensation of static misalignments

Bearings with a spherical outer ring, fitted in housings with a concave bore, can compensate for static misalignment of the shaft, *Figure 3*:

- with relubrication, up to $\pm 2,5^\circ$
- without relubrication, up to $\pm 5^\circ$.



The units must not be used to support swivelling or tumbling motion.

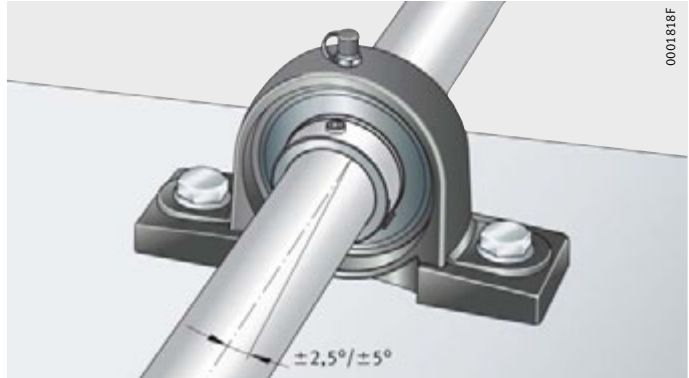

Figure 3
 Compensation of static shaft misalignment

Axial load carrying capacity of location method

The axial load carrying capacity of the location method of the radial insert ball bearing on the shaft can be derived from the diagram, *Figure 4*.

The preconditions are as follows:

- The shaft must be designed in accordance with the data in the diagram, *Figure 4*.
- The bearings must be located using the specified tightening torque M_A , see table, page 29.



If very high axial loads are present, the forces should be directed through a shoulder on the shaft. If the bearing is subjected to its maximum permissible axial load, please contact us.

F_a = axial load carrying capacity of location method
 d = bearing bore diameter

- ① Adapter sleeve
- ② Grub screw and hard, ground shafts
- ③ Grub screw and soft shaft

Figure 4
 Axial load carrying capacity of location method

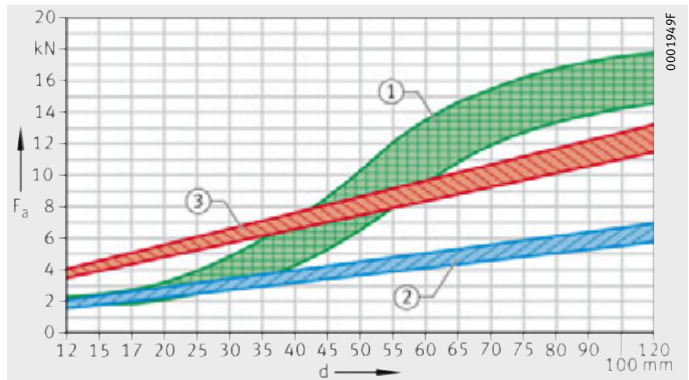

Radial insert ball bearings

Speed limits for radial insert ball bearings

The speed limits are dependent on the load, the clearance between the bearing bore and shaft and the friction of the seals in the case of bearings with contact seals.

Guide values for the permissible speeds can be derived from the diagram, *Figure 5*.

In the case of load ratios $C_r/P > 13$, the speeds can be increased. At $C_r/P < 5$, location by means of a fit is recommended, see section Conditions of rotation, chapter Technical principles, Catalogue HR 1, Rolling Bearings. For both types of applications, please contact us.

Example of permissible speed calculation

Given:

- Shaft tolerance h6
- Radial insert ball bearing UC206
- Basic dynamic load rating C_r 19 500 N
- Load P 1 300 N
- Sealing Seals RSR.

Required:

- Load ratio $C_r/P = 19\,500\text{ N}/1\,300\text{ N}$ $C_r/P > 13$
- Permissible speed $n \approx 4\,300\text{ min}^{-1}$, *Figure 5*.

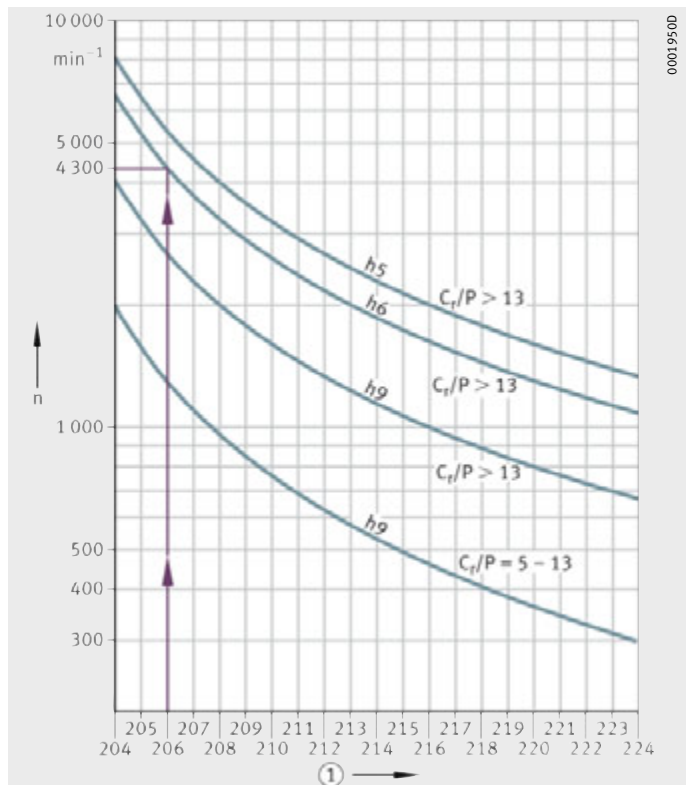

n = permissible speed

① Ball set (bearings of sizes 201, 202, 203 and 204 all have the ball set 204)

Figure 5
Permissible speed for radial insert ball bearings with seals RSR

Shaft tolerances for radial insert ball bearings

The permissible shaft tolerance is dependent on the speed and load. Tolerances h6 to h9 are recommended.

Conventional drawn shafts will suffice for most applications.

Accuracy Standard tolerances of radial insert ball bearings

The outside diameter tolerances of the bearings conform to the tolerances in accordance with JIS B 1558. The inner ring bore has a plus tolerance to allow easier mounting of the bearing, see tables.

Inner ring tolerances

Nominal bearing bore diameter d mm		Variation ¹⁾ Δ_{dmp} μm		Width deviation Δ_{Bs} μm	
over	incl.	min.	max.	min.	max.
10	18	0	+15	-120	0
18	31,75	0	+18	-120	0
31,75	50,8	0	+21	-120	0
50,8	80,962	0	+24	-150	0
80,962	120	0	+28	-200	0

¹⁾ This corresponds to the arithmetic mean value derived from the largest and smallest diameters (measured using a two-point measuring device).

Outer ring tolerances

Nominal outside diameter D_{sp} mm		Variation ¹⁾ Δ_{Dm} μm	
over	incl.	min.	max.
30	50	-11	0
50	80	-13	0
80	120	-15	0
120	150	-18	0
150	180	-25	0
180	250	-30	0

¹⁾ In the case of sealed bearings, the largest and smallest values of the outside diameter can deviate from the mean value by approx. 0,03 mm.

Radial insert ball bearings

Radial internal clearance of radial insert ball bearings

The radial internal clearance in accordance with JIS B 1520 is C3 for radial insert ball bearings UC and C4 for radial insert ball bearings UK. It is thus larger than in the case of normal deep groove ball bearings, see table.

The larger internal clearance allows better support of misalignments and shaft deflection.

Radial internal clearance

Bore		Outside diameter D mm	Radial internal clearance			
d mm	inch		C3 μm		C4 μm	
			min.	max.	min.	max.
12	–	40	11	25	18	33
12,7	1/2					
14,288	9/16					
15	–					
15,875	5/8					
17	–					
17,462	11/16					
19,05	3/4	47	13	28	20	36
20	–					
20,638	13/16	52	13	28	23	41
22,225	7/8					
23,812	15/16					
25	–					
25,4	1					
26,988	1 1/16					
28,575	1 1/8					
30	–	62	15	33	28	46
30,162	1 3/16					
31,75	1 1/4					
31,75	1 1/4					
33,338	1 5/16					
34,925	1 3/8					
35	–					
36,512	1 7/16					
38,1	1 1/2	80	18	36	30	51
39,688	1 9/16					
40	–					
41,275	1 5/8	85	18	36	30	51
42,862	1 11/16					
44,45	1 3/4					
45	–					
46,038	1 13/16	90	18	36	30	51
47,625	1 7/8					
49,212	1 15/16					
50	–					
50,8	2					

**Radial internal clearance
(continued)**

Bore		Outside diameter D	Radial internal clearance			
d			C3		C4	
mm	inch		μm		μm	
			min.	max.	min.	max.
50,8	2	100	23	43	38	61
52,388	2 ¹ / ₁₆					
53,975	2 ¹ / ₈					
55	–					
55,562	2 ³ / ₁₆					
57,15	2 ¹ / ₄	110	23	43	38	61
58,738	2 ⁵ / ₁₆					
60	–					
60,325	2 ³ / ₈					
61,912	2 ⁷ / ₁₆					
63,5	2 ¹ / ₂	120	23	43	38	61
65	–					
66,675	2 ⁵ / ₈					
68,262	2 ¹¹ / ₁₆					
69,85	2 ³ / ₄					
70	–	125	25	51	46	71
71,438	2 ¹³ / ₁₆					
73,025	2 ⁷ / ₈					
74,612	2 ¹⁵ / ₁₆					
75	–					
76,2	3	130	25	51	46	71
79,375	3 ¹ / ₈					
80	–					
80,962	3 ³ / ₁₆					
82,55	3 ¹ / ₄					
85	–	140	30	58	53	84
85,725	3 ³ / ₈					
87,312	3 ⁷ / ₁₆					
88,9	3 ¹ / ₂					
88,9	3 ¹ / ₂					
90	–	150	30	58	53	84
93,662	3 ¹¹ / ₁₆					
95	–					
100	–					
100,012	3 ¹⁵ / ₁₆					
101,6	4	160	30	58	53	84
		170	30	58	53	84
		180	30	58	53	84

Radial insert ball bearings with grub screws in the inner ring

Spherical outer ring

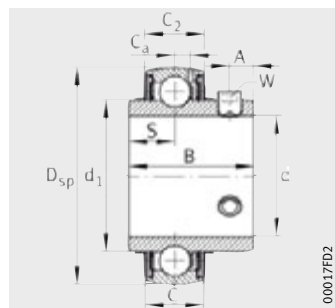

UC

Dimension table · Dimensions in mm and inch														
Designation	Mass m ≈kg	Dimensions										Basic load ratings		
		d		D _{sp}	C	C ₂	B	S	d ₁	C _a	A	W	dyn. C _r N	stat. C _{0r} N
		mm	inch											
UC201	0,2	12	–	47	17	16,8	31	12,7	27,56	4,2	5	3	12 800	6 600
UC201-08	0,2	12,7	1/2									1/8		
UC202-09	0,19	14,29	9/16									1/8		
UC202	0,18	15	–									3		
UC202-10	0,18	15,88	5/8									1/8		
UC203	0,17	17	–									3		
UC203-11	0,17	17,46	11/16									1/8		
UC204-12	0,16	19,05	3/4									1/8		
UC204	0,15	20	–									3		
UC205-13	0,24	20,64	13/16	52	17	17,6	34,1	14,3	33,83	4,2	5	1/8	14 000	7 800
UC205-14	0,22	22,23	7/8									1/8		
UC205-15	0,21	23,81	15/16									1/8		
UC205	0,2	25	–									3		
UC205-16	0,19	25,4	1									1/8		
UC206-17	0,35	26,99	1 ¹ /16	62	19	19,6	38,1	15,9	40,2	5	5	1/8	19 500	11 300
UC206-18	0,33	28,58	1 ¹ /8									1/8		
UC206	0,31	30	–									3		
UC206-19	0,31	30,16	1 ³ /16									1/8		
UC206-20	0,29	31,75	1 ¹ /4									1/8		
UC207-20	0,52	31,75	1 ¹ /4	72	20	20,6	42,9	17,5	46,84	5,7	7	5/32	25 500	15 300
UC207-21	0,5	33,34	1 ⁵ /16									5/32		
UC207-22	0,47	34,93	1 ³ /8									5/32		
UC207	0,47	35	–									4		
UC207-23	0,44	36,51	1 ⁷ /16									5/32		
UC208-24	0,66	38,1	1 ¹ /2	80	21	21,6	49,2	19	52,27	6,2	8	5/32	32 500	19 800
UC208-25	0,63	39,69	1 ⁹ /16									5/32		
UC208	0,62	40	–									4		
UC209-26	0,79	41,28	1 ⁵ /8	85	22	22,6	49,2	19	57,91	6,3	8	5/32	32 500	20 400
UC209-27	0,75	42,86	1 ¹¹ /16									5/32		
UC209-28	0,71	44,45	1 ³ /4									5/32		
UC209	0,7	45	–									4		
UC210-29	0,92	46,04	1 ¹³ /16									90		
UC210-30	0,87	47,63	1 ⁷ /8	3/16										
UC210-31	0,82	49,21	1 ¹⁵ /16	3/16										
UC210	0,8	50	–	5										
UC210-32	0,77	50,8	2	3/16										

Radial insert ball bearings with grub screws in the inner ring

Spherical outer ring

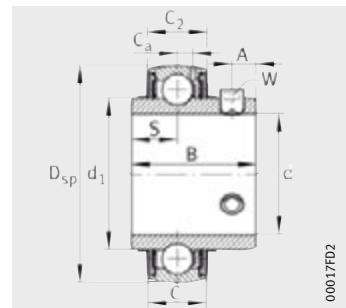

UC

Dimension table (continued) · Dimensions in mm and *inch*

Designation	Mass m ≈kg	Dimensions										Basic load ratings		
		d		D _{sp}	C	C ₂	B	S	d ₁	C _a	A	W	dyn. C _r N	stat. C _{0r} N
		mm	<i>inch</i>											
UC211-32	1,22	50,8	2	100	25	25,6	55,6	22,2	69,77	7	10	43 500	29 000	
UC211-33	1,17	52,39	2 ¹ / ₁₆											
UC211-34	1,11	53,98	2 ¹ / ₈											
UC211	1,07	55	–											
UC211-35	1,05	55,56	2 ³ / ₁₆											
UC212-36	1,62	57,15	2 ¹ / ₄	110	27	27,6	65,1	25,4	76,48	7,4	10	52 000	36 000	
UC212-37	1,55	58,74	2 ⁵ / ₁₆											
UC212	1,49	60	–											
UC212-38	1,48	60,33	2 ³ / ₈											
UC212-39	1,4	61,91	2 ⁷ / ₁₆											
UC213-40	1,82	63,5	2 ¹ / ₂	120	28	29,4	65,1	25,4	80,85	8,2	12	57 000	40 000	
UC213	1,73	65	–											
UC213-41	1,72	65,09	2 ⁹ / ₁₆											
UC214-42	2,17	66,68	2 ⁵ / ₈											
UC214-43	2,07	68,26	2 ¹¹ / ₁₆											
UC214-44	1,97	69,85	2 ³ / ₄	125	30	31,4	74,6	30,2	85,2	8,5	12	62 000	44 000	
UC214	1,97	70	–											
UC215-45	2,38	71,44	2 ¹³ / ₁₆											
UC215-46	2,27	73,03	2 ⁷ / ₈											
UC215-47	2,16	74,61	2 ¹⁵ / ₁₆											
UC215	2,13	75	–	130	32	33,4	77,8	33,3	90	8,5	12	62 000	44 500	
UC215-48	2,05	76,2	3											
UC216-49	2,88	77,79	3 ¹ / ₁₆											
UC216-50	2,76	79,38	3 ¹ / ₈											
UC216	2,71	80	–											
UC216-51	2,63	80,96	3 ³ / ₁₆	140	33	34,4	82,6	33,3	97	9,3	14	72 000	54 000	
UC217-52	3,8	82,55	3 ¹ / ₄											
UC217-53	3,64	84,14	3 ⁵ / ₁₆											
UC217	3,56	85	–											
UC217-55	3,33	87,31	3 ⁷ / ₁₆											
UC218-56	4,19	88,9	3 ¹ / ₂	160	38	39,4	96	39,7	109,4	11	15	96 000	72 000	
UC218	4,08	90	–											

Radial insert ball bearings with adapter sleeve

Spherical outer ring

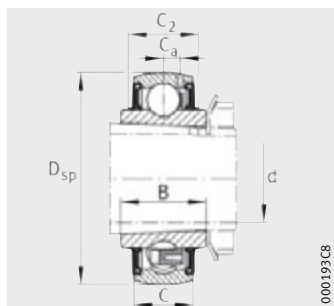

UK

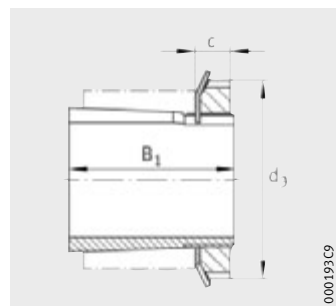

Complete adapter sleeve

Dimension table · Dimensions in mm

Designation	Mass m ≈kg	Dimensions						Basic load ratings	
		d	D _{sp}	C	C ₂	B	C _a	dyn. C _r N	stat. C _{0r} N
UK205	0,25	20	52	17	17,6	23	4,2	14 000	7 800
UK206	0,38	25	62	19	19,6	26	5	19 500	11 300
UK207	0,55	30	72	20	20,6	29	5,7	25 500	15 300
UK208	0,7	35	80	21	21,6	31	6,2	32 500	19 800
UK209	0,83	40	85	22	22,6	32	6,3	32 500	20 400
UK210	0,98	45	90	24	24,6	34	6,5	35 000	23 200
UK211	1,24	50	100	25	25,6	36	7	43 500	29 000
UK212	1,58	55	110	27	27,6	40	7,4	52 000	36 000
UK213	1,88	60	120	28	29,4	40	8,2	57 000	40 000
UK215	2,58	65	130	32	33,4	41,5	8,5	62 000	44 500
UK216	3,21	70	140	33	34,4	44	9,3	72 000	54 000
UK217	3,81	75	150	35	36,4	46	10	88 000	64 000
UK218	4,59	80	160	38	39,4	49	11	96 000	72 000

Designation					Mass m ≈kg	Dimensions		
Adapter sleeve Complete	Sleeve	Locknut	Tab washer	Matching bearing		B ₁	c	d ₃ max.
H2305	A2305X	AN05	AW05X	UK205	0,1	35	8	38
H2306	A2306X	AN06	AW06X	UK206	0,13	38	8	45
H2307	A2307X	AN07	AW07X	UK207	0,18	43	9	52
H2308	A2308X	AN08	AW08X	UK208	0,23	46	10	58
H2309	A2309X	AN09	AW09X	UK209	0,31	50	11	65
H2310	A2310X	AN10	AW10X	UK210	0,38	55	12	70
H2311	A2311X	AN11	AW11X	UK211	0,45	59	12	75
H2312	A2312X	AN12	AW12X	UK212	0,5	62	13	80
H2313	A2313X	AN13	AW13X	UK213	0,56	65	14	85
H2315	A2315X	AN15	AW15X	UK215	1,05	73	15	98
H2316	A2316X	AN16	AW16X	UK216	1,3	78	17	105
H2317	A2317X	AN17	AW17X	UK217	1,45	82	18	110
H2318	A2318X	AN18	AW18X	UK218	1,7	86	18	120

FAG



Housing units

Housing units

	Page
Product overview	Housing units 20
Features	Housing units with flake graphite cast iron housing 22
Design and safety guidelines	Compensation of static misalignments 26
	Load carrying capacity of housings 26
	Load carrying capacity and speed limits of radial insert ball bearings 26
	Design of adjacent construction 26
	Fitting and dismantling 27
Accuracy	Dimensional tolerances 30
Dimension tables	Plummer block housing units, flake graphite cast iron housing with long base with grub screws in inner ring 32
	with adapter sleeve 36
	Plummer block housing units, flake graphite cast iron housing with short base with grub screws in inner ring 38
	Two-bolt flanged housing units, flake graphite cast iron housing with grub screws in inner ring 40
	with adapter sleeve 42
	Three-bolt flanged housing units, flake graphite cast iron housing with grub screws in inner ring 44
	Four-bolt flanged housing units, square version with grub screws in inner ring 46
	with adapter sleeve 48
	Four-bolt flanged housing units, round version with grub screws in inner ring 50
	with adapter sleeve 54
	Take-up housing units, for linear motion with grub screws in inner ring 56
	with adapter sleeve 60
	Take-up housing units, for swivel motion with grub screws in inner ring 62

Product overview Housing units

Plummer block housing units

Flake graphite cast iron housing with long base



Flake graphite cast iron housing with short base



Two-bolt flanged housing units

Flake graphite cast iron housing



Three-bolt flanged housing units

Flake graphite cast iron housing



Four-bolt flanged housing units

Flake graphite cast iron housing

UCF

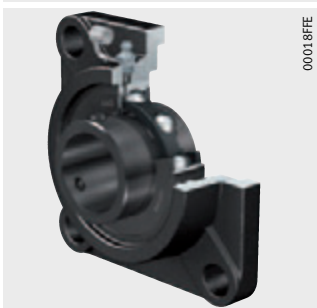

UKF



UCFC



UKFC



Take-up housing units

Flake graphite cast iron housing

UCT



UKT



UCFA



Housing units

Features These housing units are available as plummer block housing units, flanged housing units and take-up housing units. The units are ready-to-fit and comprise FAG flake graphite cast iron housings in which FAG Black Series radial insert ball bearings are fitted. In order to ensure function and reliability under all operating conditions, the bearings and housings are matched to each other. Due to the spherical outer ring of the bearing and the concave housing bore, housing units can compensate for static misalignments of the shaft, see page 26. The housings are screw mounted on the adjacent construction. Less stringent tolerances are sufficient for the screw mounting surfaces, see page 26.

Housing units with flake graphite cast iron housing

The flake graphite cast iron housings are single piece components in accordance with JIS B 1559 and have high radial and axial load carrying capacity, see page 26.

The housing has a lubrication groove for relubrication of the radial insert ball bearing. The housing has a lubrication hole with an M6 thread for a lubrication nipple.

The housings have a primer paint coating as anti-corrosion protection of colour RAL 9005 (black).

Housing material

The material used for the flake graphite cast iron housings is cast iron in accordance with JIS G 5501.

Plummer block housing units

Plummer block housing units have a housing with a short or long base and are screw mounted to the adjacent construction through slot holes or fixing holes, *Figure 1* and *Figure 2*, page 23.

Plummer block housing units with a long base are available either with radial insert ball bearings UC with grub screws or with radial insert ball bearings UK with adapter sleeves, see dimension table.

UCP

Figure 1
Plummer block housing unit,
flake graphite cast iron housing
with long base

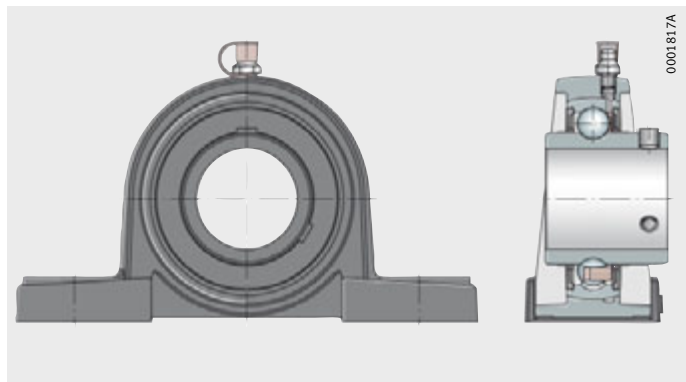

UCPA

Figure 2
Plummer block housing units
with short base

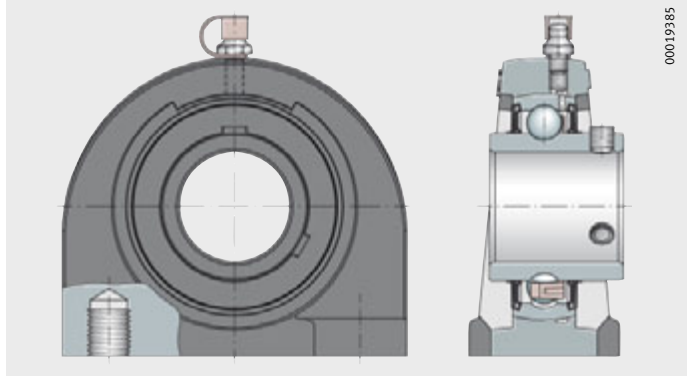

Flanged housing units

Flanged housing units are available as two-bolt, three-bolt and four-bolt units, *Figure 3* to *Figure 6*, page 24. The housings are oval, square or round in shape. The housings have through holes for location purposes.

Flanged housing units are available either with radial insert ball bearings UC with grub screws or with radial insert ball bearings UK with adapter sleeves, see dimension table.

UCFL

Figure 3
Two-bolt flanged housing unit,
oval version

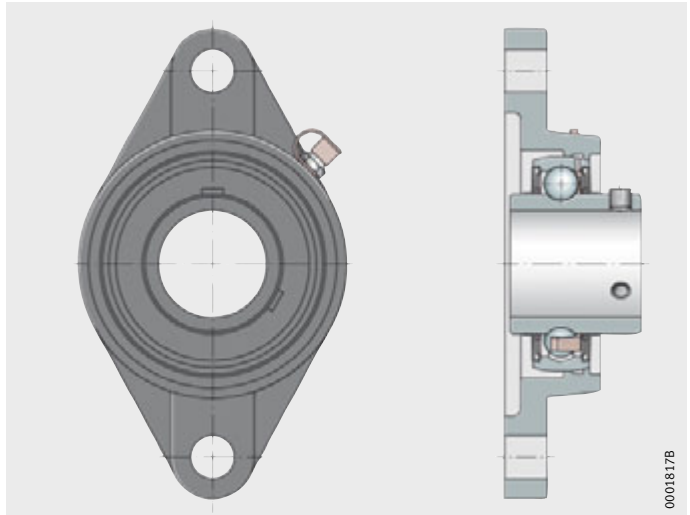

UCFB

Figure 4
Three-bolt flanged housing unit

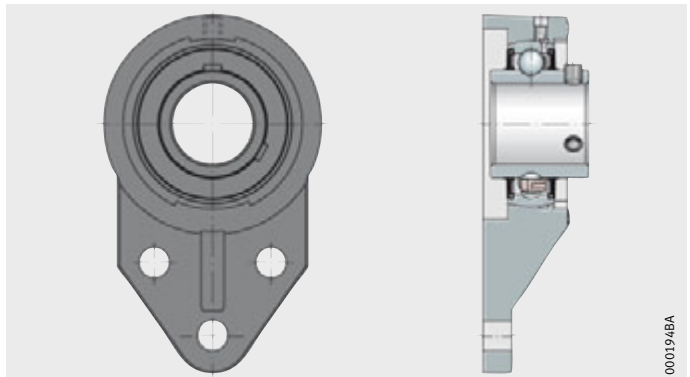

Housing units

UCF

Figure 5
Four-bolt flanged housing unit,
square version

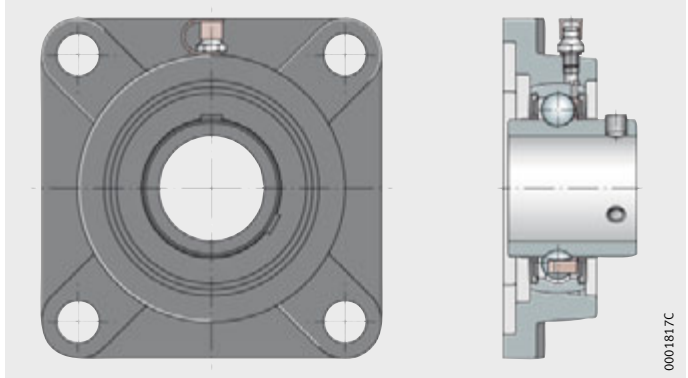

UCFC

Figure 6
Four-bolt flanged housing unit,
round version

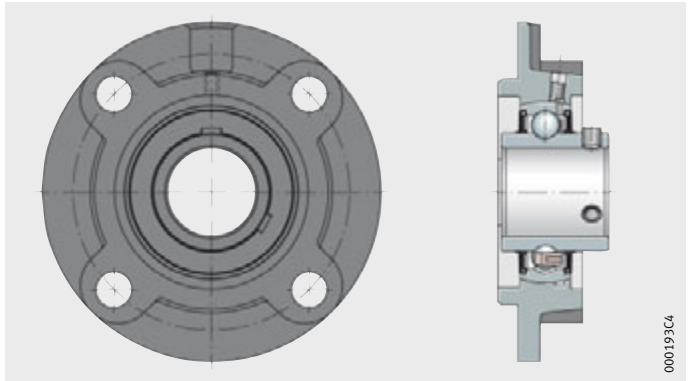

Take-up housing units

Take-up housing units can be moved or swivelled, *Figure 7* and *Figure 8*. They are used where shafts must carry out long displacement motions.

UCT

Figure 7
Take-up housing unit
for linear motion

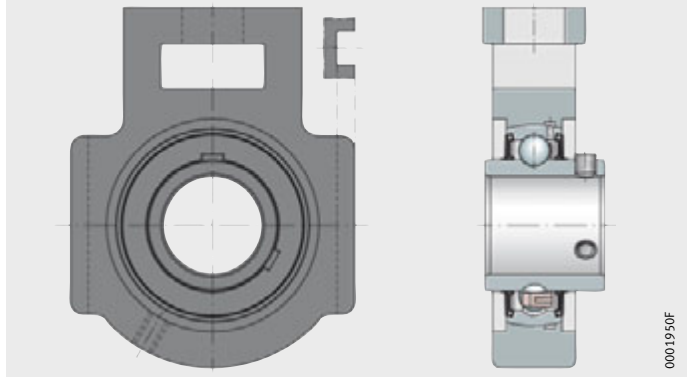

UCFA

Figure 8
Take-up housing unit
for swivel motion

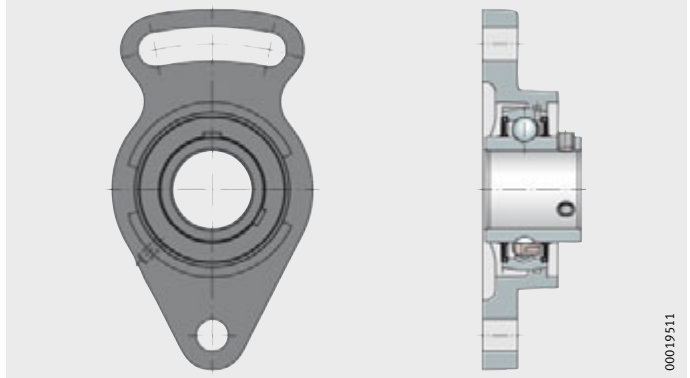

Housing units

Design and safety guidelines Compensation of static misalignments

Units with a spherical outer ring and concave housing bore can compensate static misalignments of the shaft, see page 9.

Load carrying capacity of housings

Due to their versatile characteristics, FAG housing units can be easily used in almost all industrial sectors.

Radial load carrying capacity

Flake graphite cast iron housings can support the same radial loads as the insert bearings fitted. The static load carrying capacity C_{0r} of the radial insert ball bearings is stated in the dimension tables.



Where shock loads are present, appropriate safety factors must be applied. In this case, please contact us.

Axial load carrying capacity

The axial load carrying capacity of flake graphite cast iron housings is restricted to $0,5 \times C_{0r}$.

Load carrying capacity and speed limits of radial insert ball bearings



In the design of housing units, attention must be paid to the load carrying capacity and speed limits of the radial insert ball bearings fitted:

- axial load carrying capacity, see page 9
- speed limits, see page 10
- dimension table, see page 14.

Design of adjacent construction

The permissible shaft tolerance is dependent on the speed and load. Shafts in the tolerance zone h6 to h9 can be used.

Screw mounting surfaces

Recommendations for the screw mounting surfaces are as follows:

- roughness of the screw mounting surface max. Ra12,5 (Rz63)
- geometrical tolerance 0,04/100 concave, spherical not permissible
- In addition, it is recommended that the housings should be secured by dowels to the locating surface if higher loads acting parallel to the locating surface occur.

Fixing screws

The screw connection should be designed in accordance with the state of the art. Screws of grade 8.8 can be used. The maximum tightening torques applicable to this screw grade must not be exceeded even if screws of a higher grade are used.

In principle, we recommend that the screw connection should only be tightened to 70% of the values stated in the standard.

Screws and accessories for location are not included in the delivery.

Fitting and dismantling	Radial insert ball bearings must be handled with care before and during mounting. Their trouble-free operation is also dependent on the care taken during fitting.
Delivered condition	<p>The housings have a coating of black primer paint (RAL 9005).</p> <p>The radial insert ball bearings are greased using a grease in grease group GA13, see Catalogue HR 1, Rolling Bearings.</p> <p>The housing units are supplied with a loose packed lubrication nipple and integrated end cap for the lubrication nipple as well as an Allen key.</p>
Storage and shelf life	<p>The units should be stored in dry, clean rooms with a temperature as constant as possible and at a relative humidity of max. 65%.</p> <p>The storage life of radial insert ball bearings is limited by the shelf life of the grease, see chapter Technical principles in Catalogue HR 1, Rolling Bearings.</p>
Removal from packaging	Perspiration causes corrosion. Hands must therefore be kept clean and dry. Bearings should not be removed from their original packaging until immediately before fitting.
Preparation for fitting	<p>The following preparatory measures for fitting should be taken:</p> <ul style="list-style-type: none"> ■ Ensure that the fitting tools and fixing screws are present. ■ Clean the shaft and remove any burrs. ■ Inspect the bearing seating surfaces on the shaft. ■ Keep bearing seating surfaces clean, dry and free of grease.

Housing units

Fitting of plunger block and flanged housing units



The assembly area should be as dry and clean as possible:

- The specified shaft tolerances must be observed, see page 26.
- Fitting forces must never be directed through the rolling elements.
- Blows should never be applied directly to the bearing rings and flinger shields or seals.
- Observe the tightening torques M_A for grub screws and adapter sleeve, see tables, page 29.

If the following sequence is observed, the bearing will align itself on the shaft in such a way that no undesirable stresses occur:

- ▶ Slide the housing unit onto the shaft and align it with the fixing holes in the adjacent construction, *Figure 9*.
- ▶ Tighten the fixing screws for all housings finger tight in the adjacent construction and align the shaft, *Figure 10*.
- ▶ Tighten both grub screws in the inner ring (for radial insert ball bearing UC) or the locknut of the adapter sleeve (for radial insert ball bearing UK) using a tightening torque (with an additional adapter if necessary) to the specified tightening torque, *Figure 11*, page 29.
- ▶ Locate the housings on the adjacent construction using the recommended tightening torque, see page 26.

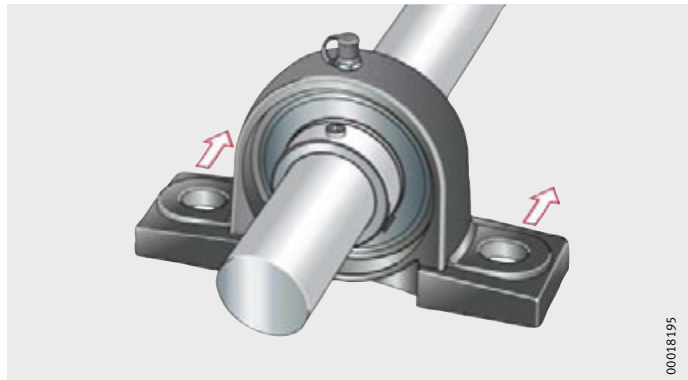

Figure 9
Sliding the unit onto the shaft

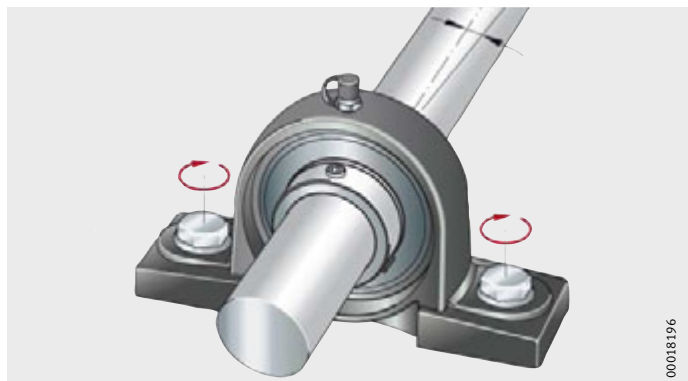

Figure 10
Screw mounting
the housing finger tight

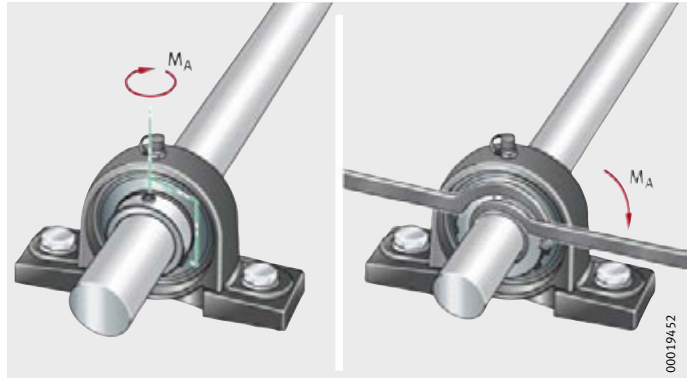

Figure 11
Fully tightening the grub screws or
locknut in the inner ring

Tightening torques for grub screws

Width across flats W		Thread		Tightening torques ¹⁾ M_A
mm	inch	ISO	UNF	Nm
2,5	$\frac{3}{32}$	M5	N10-32	3,6
3	$\frac{1}{8}$	M6×0,75	1/4"-28	6
4	$\frac{5}{32}$	M8×1	5/16"-24	14
5	$\frac{3}{16}$	M10×1,25	3/8"-24	26
6	$\frac{1}{4}$	M12	1/2"-20	42

¹⁾ The tightening torques are valid for original FAG grub screws only.

Tightening torques for locknut

Locknut	Tightening torques M_A Nm
AN05	25
AN06	30
AN07	40
AN08	50
AN09	60
AN10	75
AN11	100
AN12	130
AN13	150
AN15	170
AN16	200
AN17	230
AN18	270

Dismantling

The units are dismantled in the reverse sequence.

- ▶ Loosen the grub screws in the inner ring or the locknut of the adapter sleeve.
- ▶ Unscrew the housing.

Housing units

Accuracy The flake graphite cast iron housings conform to JIS B 1559.
Accuracy of fitted radial insert ball bearings: see page 11.

Dimensional tolerances The dimensional tolerances for the machined surfaces of the flake graphite cast iron housings are $\pm 0,25$ mm.
Dimensions without tolerance conform to JIS B 0403:

- unfinished dimensions to Table 1, class CT 10
- finished dimensions to Table 5.

Plummer block housing units

Flake graphite cast iron housings
with long base
With grub screws in inner ring

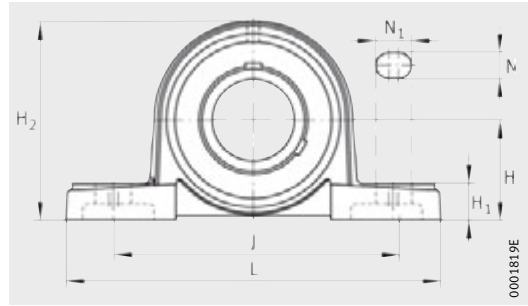

UCP

Dimension table · Dimensions in mm and *inch*

Designation	Mass m ≈kg	Dimensions		H	L	J
		d				
		mm	<i>inch</i>			
UCP201	0,7	12	–	30,2	127	95
UCP201-08	0,69	12,7	1/2			
UCP202-09	0,69	14,288	9/16			
UCP202	0,68	15	–			
UCP202-10	0,68	15,875	5/8			
UCP203	0,67	17	–			
UCP203-11	0,67	17,463	11/16			
UCP204-12	0,66	19,05	3/4	33,3		
UCP204	0,65	20	–			
UCP205-13	0,83	20,638	13/16	36,5	140	105
UCP205-14	0,82	22,225	7/8			
UCP205-15	0,81	23,813	15/16			
UCP205	0,79	25	–			
UCP205-16	0,79	25,4	1			
UCP206-17	1,33	26,988	11/16	42,9	165	121
UCP206-18	1,31	28,575	11/8			
UCP206	1,29	30	–			
UCP206-19	1,29	30,163	13/16			
UCP206-20	1,27	31,75	11/4			
UCP207-20	1,6	31,75	11/4	47,6	167	127
UCP207-21	1,58	33,338	15/16			
UCP207-22	1,55	34,925	13/8			
UCP207	1,55	35	–			
UCP207-23	1,52	36,513	17/16			
UCP208-24	1,89	38,1	11/2	49,2	184	137
UCP208-25	1,85	39,688	19/16			
UCP208	1,84	40	–			
UCP209-26	2,29	41,275	15/8	54	190	146
UCP209-27	2,25	42,863	111/16			
UCP209-28	2,21	44,45	13/4			
UCP209	2,2	45	–			
UCP210-29	2,89	46,038	113/16	57,2	206	159
UCP210-30	2,85	47,625	17/8			
UCP210-31	2,8	49,213	115/16			
UCP210	2,77	50	–			
UCP210-32	2,75	50,8	2			

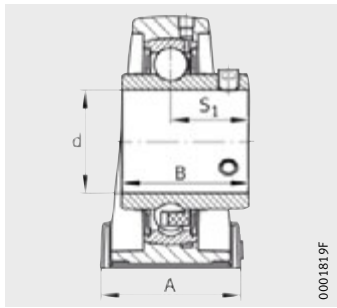

UCP

0001819F

							Housing	Radial insert ball bearing
A	N ₁	N	H ₁	H ₂	B	S ₁		
38	19	13	14	62	31	18,3	P203	UC201
								UC201-08
								UC202-09
								UC202
				65	P204	UC202-10		
						UC203		
						UC203-11		
						UC204-12		
38	19	13	15	71	34,1	19,8	P205	UC204
								UC205-13
48	21	17	17	83	38,1	22,2	P206	UC205-14
								UC205-15
								UC205
								UC205-16
								UC206-17
48	21	17	18	93	42,9	25,4	P207	UC206-18
								UC206
								UC206-19
								UC206-20
								UC207-20
54	21	17	18	98	49,2	30,2	P208	UC207-21
								UC207-22
								UC207
54	21	17	20	106	49,2	30,2	P209	UC207-23
								UC208-24
								UC208-25
								UC208
60	25	20	21	114	51,6	32,6	P210	UC209-26
								UC209-27
								UC209-28
								UC209
								UC210-29
60	25	20	21	114	51,6	32,6	P210	UC210-30
								UC210-31
								UC210
								UC210-32

Plummer block housing units

Flake graphite cast iron housings
with long base
With grub screws in inner ring

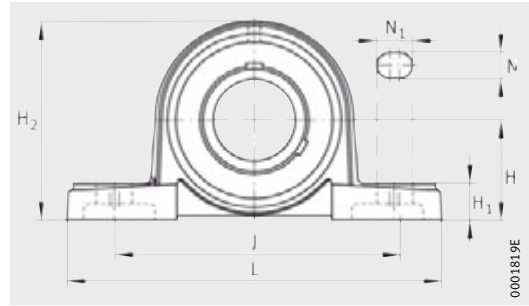

UCP

Dimension table (continued) · Dimensions in mm and *inch*

Designation	Mass m ≈kg	Dimensions		H	L	J
		d				
		mm	<i>inch</i>			
UCP211-32	3,56	50,8	2	63,5	219	171
UCP211-33	3,5	52,388	$2^1/16$			
UCP211-34	3,44	53,975	$2^1/8$			
UCP211	3,41	55	–			
UCP211-35	3,39	55,563	$2^3/16$			
UCP212-36	4,75	57,15	$2^1/4$	69,8	241	184
UCP212-37	4,68	58,738	$2^5/16$			
UCP212	4,62	60	–			
UCP212-38	4,6	60,325	$2^3/8$			
UCP212-39	4,53	61,913	$2^7/16$			
UCP213-40	5,66	63,5	$2^1/2$	76,2	265	203
UCP213	5,57	65	–			
UCP213-41	5,56	65,088	$2^9/16$			
UCP214-42	6,3	66,675	$2^5/8$	79,4	266	210
UCP214-43	6,2	68,263	$2^{11}/16$			
UCP214-44	6,1	69,85	$2^3/4$			
UCP214	6,1	70	–			
UCP215-45	6,93	71,438	$2^{13}/16$	82,6	275	217
UCP215-46	6,79	73,025	$2^7/8$			
UCP215-47	6,71	74,613	$2^{15}/16$			
UCP215	6,68	75	–			
UCP215-48	6,6	76,2	3			
UCP216-49	8,53	77,788	$3^1/16$	88,9	292	232
UCP216-50	8,41	79,375	$3^1/8$			
UCP216	8,37	80	–			
UCP216-51	8,28	80,963	$3^3/16$			
UCP217-52	10,57	82,55	$3^1/4$	95,2	310	247
UCP217-53	10,41	84,138	$3^5/16$			
UCP217	10,33	85	–			
UCP217-55	10,1	87,313	$3^7/16$			
UCP218-56	12,31	88,9	$3^1/2$			
UCP218	12,2	90	–	101,6	327	262

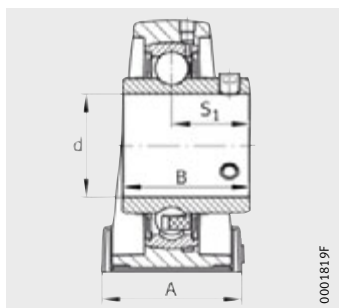

UCP

0001819F

A	N ₁	N	H ₁	H ₂	B	S ₁	Housing	Radial insert ball bearing
60	25	20	23	126	55,6	33,4	P211	UC211-32
								UC211-33
								UC211-34
								UC211
								UC211-35
70	25	20	25	138	65,1	39,7	P212	UC212-36
								UC212-37
								UC212
								UC212-38
								UC212-39
70	29	25	27	151	65,1	39,7	P213	UC213-40
								UC213
								UC213-41
72	31	25	27	157	74,6	44,4	P214	UC214-42
								UC214-43
								UC214-44
								UC214
74	31	25	28	163	77,8	44,5	P215	UC215-45
								UC215-46
								UC215-47
								UC215
								UC215-48
78	31	25	30	175	82,6	49,3	P216	UC216-49
								UC216-50
								UC216
								UC216-51
83	31	25	32	187	85,7	51,6	P217	UC217-52
								UC217-53
								UC217
								UC217-55
88	33	27	33	200	96	56,3	P218	UC218-56
								UC218

Plummer block housing units

Flake graphite cast iron housing
with long base
With adapter sleeve

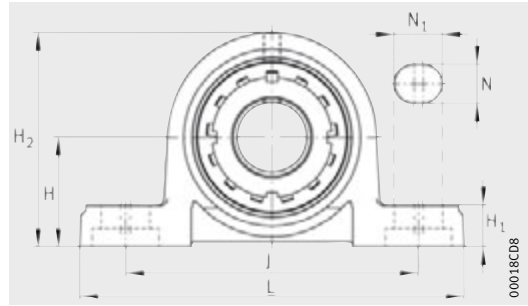

UKP

Dimension table · Dimensions in mm

Designation	Mass m ≈kg	Dimensions											Housing	Radial insert ball bearing
		d	H	L	J	A	N ₁	N	H ₁	H ₂	B ₁	d ₃ max.		
UKP205	0,84	20	36,5	140	105	38	19	13	15	71	35	38	GG.P205	UK205
UKP206	1,36	25	42,9	165	121	48	21	17	17	83	38	45	GG.P206	UK206
UKP207	1,63	30	47,6	167	127	48	21	17	18	93	43	52	GG.P207	UK207
UKP208	1,92	35	49,2	184	137	54	21	17	18	98	46	58	GG.P208	UK208
UKP209	2,33	40	54	190	146	54	21	17	20	106	50	65	GG.P209	UK209
UKP210	2,95	45	57,2	206	159	60	25	20	21	114	55	70	GG.P210	UK210
UKP211	3,58	50	63,5	219	171	60	25	20	23	126	59	75	GG.P211	UK211
UKP212	4,71	55	69,8	241	184	70	25	20	25	138	62	80	GG.P212	UK212
UKP213	5,71	60	76,2	265	203	70	29	25	27	151	65	85	GG.P213	UK213
UKP215	7,11	65	82,6	275	217	74	31	25	28	163	73	98	GG.P215	UK215
UKP216	8,86	70	88,9	292	232	78	31	25	30	175	78	105	GG.P216	UK216
UKP217	10,58	75	95,2	310	247	83	31	25	32	187	82	110	GG.P217	UK217
UKP218	12,71	80	101,6	327	262	88	33	27	33	200	86	120	GG.P218	UK218

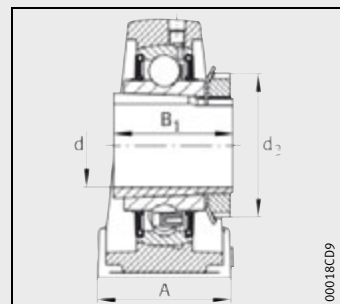

UKP

Plummer block housing units

Flake graphite cast iron housing
with short base
With grub screws in inner ring

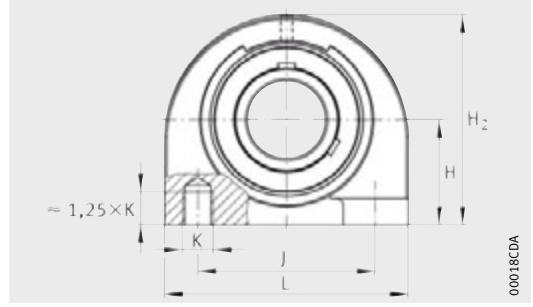

UCPA

00018CDA

Dimension table · Dimensions in mm and inch

Designation	Mass m ≈kg	Dimensions		H	A	H ₂
		d				
		mm	inch			
UCPA201	0,66	12	–	30,2	38	62
UCPA201-08	0,65	12,7	1/2			
UCPA202-09	0,65	14,288	9/16			
UCPA202	0,64	15	15			
UCPA202-10	0,64	15,875	5/8			
UCPA203	0,63	17	–			
UCPA203-11	0,63	17,463	11/16			
UCPA204-12	0,62	19,05	3/4			
UCPA204	0,61	20	–			
UCPA205-13	0,87	20,638	13/16	36,5	38	72
UCPA205-14	0,86	22,225	7/8			
UCPA205-15	0,84	23,813	15/16			
UCPA205	0,83	25	–			
UCPA205-16	0,83	25,4	1			
UCPA206-17	1,26	26,988	1 1/16	42,9	48	84
UCPA206-18	1,24	28,575	1 1/8			
UCPA206	1,22	30	–			
UCPA206-19	1,22	30,163	1 3/16			
UCPA206-20	1,2	31,75	1 1/4			
UCPA207-20	1,75	31,75	1 1/4	47,6	48	95
UCPA207-21	1,73	33,338	1 5/16			
UCPA207-22	1,7	34,925	1 3/8			
UCPA207	1,7	35	–			
UCPA207-23	1,67	36,513	1 7/16			
UCPA208-24	1,96	38,1	1 1/2	49,2	54	100
UCPA208-25	1,92	39,688	1 9/16			
UCPA208	1,91	40	–			
UCPA209-26	2,28	41,275	1 5/8	54,2	54	108
UCPA209-27	2,24	42,863	1 11/16			
UCPA209-28	2,2	44,45	1 3/4			
UCPA209	2,19	45	–			
UCPA210-29	2,9	46,038	1 13/16	57,2	60	116
UCPA210-30	2,85	47,625	1 7/8			
UCPA210-31	2,8	49,213	1 15/16			
UCPA210	2,78	50	–			
UCPA210-32	2,76	50,8	2			

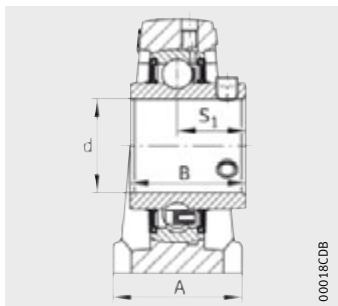

UCPA

					Housing	Radial insert ball bearing
K	B	J	S ₁	L		
M10	31	52	18,3	76	PA204	UC201
						UC201-08
						UC202-09
						UC202
						UC202-10
						UC203
						UC203-11
						UC204-12
M10	34,1	56	19,8	84	PA205	UC204
						UC205-13
						UC205-14
						UC205-15
						UC205-16
M14	38,1	66	22,2	94	PA206	UC205
						UC206-17
						UC206-18
						UC206
						UC206-19
M14	42,9	80	25,4	110	PA207	UC206-20
						UC207-20
						UC207-21
						UC207-22
M14	49,2	84	30,2	116	PA208	UC207
						UC207-23
						UC208-24
M14	49,2	90	30,2	120	PA209	UC208-25
						UC208
						UC209-26
						UC209-27
M16	51,6	94	32,6	130	PA210	UC209-28
						UC209
						UC210-29
						UC210-30
						UC210-31
						UC210
						UC210-32

Two-bolt flanged housing units

Flake graphite
cast iron housing
With grub screws
in inner ring

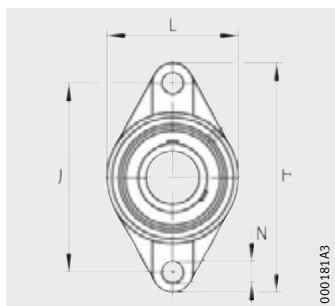

UCFL

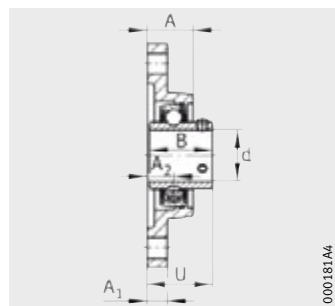

UCFL

Dimension table · Dimensions in mm and inch

Designation	Mass m ≈kg	Dimensions											Housing	Radial insert ball bearing
		d		H	J	L	A	A ₁	A ₂	N	B	U		
		mm	inch											
UCFL201	0,47	12	–	113	90	60	25,5	12	15	12	31	33,3	FL204	UC201
UCFL201-08	0,47	12,7	1/2											UC201-08
UCFL202-09	0,46	14,288	9/16											UC202-09
UCFL202	0,46	15	–											UC202
UCFL202-10	0,45	15,875	5/8											UC202-10
UCFL203	0,44	17	–											UC203
UCFL203-11	0,44	17,463	11/16											UC203-11
UCFL204-12	0,43	19,05	3/4											UC204-12
UCFL204	0,42	20	–											UC204
UCFL205-13	0,68	20,638	13/16	130	99	68	27	15	16	16	34,1	35,8	FL205	UC205-13
UCFL205-14	0,67	22,225	7/8											UC205-14
UCFL205-15	0,65	23,813	15/16											UC205-15
UCFL205	0,64	25	–											UC205
UCFL205-16	0,64	25,4	1											UC205-16
UCFL206-17	0,92	26,988	11/16	148	117	80	31	14	18	16	38,1	40,2	FL206	UC206-17
UCFL206-18	0,9	28,575	11/8											UC206-18
UCFL206	0,88	30	–											UC206
UCFL206-19	0,88	30,163	13/16											UC206-19
UCFL206-20	0,85	31,75	11/4											UC206-20
UCFL207-20	1,27	31,75	11/4	161	130	90	34	16	19	16	42,9	44,4	FL207	UC207-20
UCFL207-21	1,24	33,338	15/16											UC207-21
UCFL207-22	1,21	34,925	13/8											UC207-22
UCFL207	1,21	35	–											UC207
UCFL207-23	1,18	36,513	17/16											UC207-23
UCFL208-24	1,53	38,1	11/2	175	144	100	36	16	21	16	49,2	51,2	FL208	UC208-24
UCFL208-25	1,49	39,688	19/16											UC208-25
UCFL208	1,48	40	–											UC208
UCFL209-26	2,05	41,275	15/8	188	148	108	38	18	22	19	49,2	52,2	FL209	UC209-26
UCFL209-27	2,01	42,863	111/16											UC209-27
UCFL209-28	1,97	44,45	13/4											UC209-28
UCFL209	1,95	45	–											UC209

Two-bolt flanged housing units

Flake graphite
cast iron housing
With grub screws
in inner ring

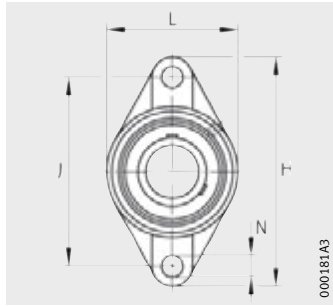

UCFL

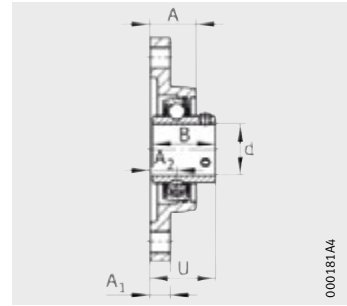

UCFL

Dimension table (continued) · Dimensions in mm and *inch*

Designation	Mass m ≈kg	Dimensions										Housing	Radial insert ball bearing	
		d		H	J	L	A	A ₁	A ₂	N	B			U
		mm	<i>inch</i>											
UCFL210-29	2,34	46,038	$1^{13}/16$	197	157	115	40	18	22	19	51,6	54,6	FL210	UC210-29
UCFL210-30	2,3	47,625	$1^7/8$											UC210-30
UCFL210-31	2,25	49,213	$1^{15}/16$											UC210-31
UCFL210	2,23	50	–											UC210
UCFL210-32	2,2	50,8	2	224	184	130	43	20	25	19	55,6	58,4	FL211	UC210-32
UCFL211-32	3,02	50,8	2											UC211-32
UCFL211-33	2,96	52,388	$2^1/16$											UC211-33
UCFL211-34	2,91	53,975	$2^1/8$											UC211-34
UCFL211	2,87	55	–	250	202	140	48	20	29	23	65,1	68,7	FL212	UC211
UCFL211-35	2,85	55,563	$2^3/16$											UC211-35
UCFL212-36	4,1	57,15	$2^1/4$											UC212-36
UCFL212-37	4,02	58,738	$2^5/16$											UC212-37
UCFL212	3,96	60	–	258	210	155	50	24	30	23	65,1	69,7	FL213	UC212
UCFL212-38	3,95	60,325	$2^3/8$											UC212-38
UCFL212-39	3,87	61,913	$2^7/16$											UC212-39
UCFL213-40	4,78	63,5	$2^1/2$											UC213-40
UCFL213	4,69	65	–	265	216	160	54	24	31	23	74,6	75,4	FL214	UC213
UCFL213-41	4,68	65,088	$2^9/16$											UC213-41
UCFL214-42	5,45	66,675	$2^5/8$											UC214-42
UCFL214-43	5,35	68,263	$2^{11}/16$											UC214-43
UCFL214-44	5,25	69,85	$2^3/4$	275	225	165	56	24	34	23	77,8	78,5	FL215	UC214-44
UCFL214	5,25	70	–											UC214
UCFL215-45	5,94	71,438	$2^{13}/16$											UC215-45
UCFL215-46	5,82	73,025	$2^7/8$											UC215-46
UCFL215-47	5,72	74,613	$2^{15}/16$	290	233	180	58	24	34	25	82,6	83,3	FL216	UC215-47
UC215	5,69	75	–											UC215
UCFL215-48	5,61	76,2	3											UC215-48
UCFL216-49	7,41	77,788	$3^1/16$											UC216-49
UCFL216-50	7,29	79,375	$3^1/8$	305	248	190	63	26	36	25	85,7	87,6	FL217	UC216-50
UCFL216	7,24	80	–											UC216
UCFL216-51	7,16	80,963	$3^3/16$											UC216-51
UCFL217-52	9,01	82,55	$3^1/4$											UC217-52
UCFL217-53	8,85	84,138	$3^5/16$	320	265	205	68	26	40	25	96	96,3	FL218	UC217-53
UCFL217	8,77	85	–											UC217
UCFL217-55	8,54	87,313	$3^7/16$											UC217-55
UCFL218-56	10,51	88,9	$3^1/2$											UC218-56
UCFL218	10,4	90	–	UC218										

Two-bolt flanged housing units

Flake graphite
cast iron housing
With adapter sleeve

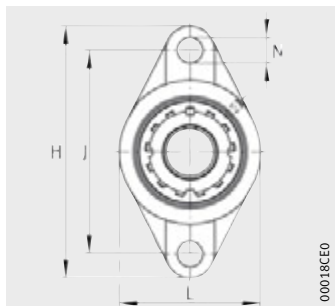

UKFL

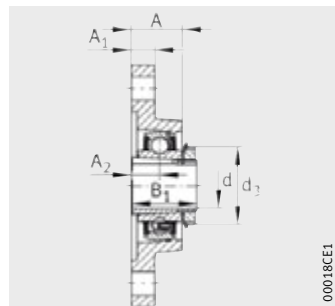

UKFL

Dimension table · Dimensions in mm

Designation	Mass m ≈kg	Dimensions										Housing	Radial insert ball bearing	
		d	H	J	L	A	A ₁	A ₂	N	B ₁	d ₃ max.			
UKFL205	0,69	20	130	99	68	27	15	16	16	16	35	38	FL205	UK205
UKFL206	0,94	25	148	117	80	31	14	18	16	16	38	45	FL206	UK206
UKFL207	1,29	30	161	130	90	34	16	19	16	16	43	52	FL207	UK207
UKFL208	1,56	35	175	144	100	36	16	21	16	16	46	58	FL208	UK208
UKFL209	2,08	40	188	148	108	38	18	22	19	19	50	65	FL209	UK209
UKFL210	2,4	45	197	157	115	40	18	22	19	19	55	70	FL210	UK210
UKFL211	3,04	50	224	184	130	43	20	25	19	19	59	75	FL211	UK211
UKFL212	4,05	55	250	202	140	48	20	29	23	23	62	80	FL212	UK212
UKFL213	4,84	60	258	210	155	50	24	30	23	23	65	85	FL213	UK213
UKFL215	6,14	65	275	225	165	56	24	34	23	23	73	98	FL215	UK215
UKFL216	7,74	70	290	233	180	58	24	34	25	25	78	105	FL216	UK216
UKFL217	9,02	75	305	248	190	63	26	36	25	25	82	110	FL217	UK217
UKFL218	10,91	80	320	265	205	68	26	40	25	25	86	120	FL218	UK218

Three-bolt flanged housing units

Flake graphite
cast iron housing
With grub screws
in inner ring

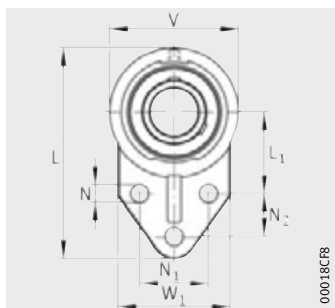

UCFB

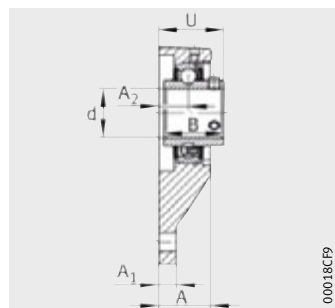

UCFB

Dimension table · Dimensions in mm and *inch*

Designation	Mass m ≈kg	Dimensions					
		d		L	L ₁	V	W ₁
		mm	<i>inch</i>				
UCFB201	0,57	12	–	110	42	62	52
UCFB201-08	0,57	12,7	1/2				
UCFB202-09	0,56	14,288	9/16				
UCFB202	0,56	15	–				
UCFB202-10	0,55	15,875	5/8				
UCFB203	0,54	17	–				
UCFB203-11	0,54	17,463	11/16				
UCFB204-12	0,53	19,05	3/4				
UCFB204	0,52	20	–				
UCFB205-13	0,66	20,638	13/16	116	45	68	56
UCFB205-14	0,65	22,225	7/8				
UCFB205-15	0,63	23,813	15/16				
UCFB205	0,62	25	–				
UCFB205-16	0,62	25,4	1				
UCFB206-17	0,89	26,988	11/16	130	50	78	65
UCFB206-18	0,87	28,575	11/8				
UCFB206	0,85	30	–				
UCFB206-19	0,85	30,163	13/16				
UCFB206-20	0,83	31,75	11/4				
UCFB207-20	1,24	31,75	11/4	144	55	90	70
UCFB207-21	1,22	33,338	15/16				
UCFB207-22	1,19	34,925	13/8				
UCFB207	1,19	35	–				
UCFB207-23	1,16	36,513	17/16				
UCFB208-24	1,67	38,1	11/2	164	60	100	78
UCFB208-25	1,64	39,688	19/16				
UCFB208	1,63	40	–				
UCFB209-26	1,97	41,275	15/8	174	65	106	80
UCFB209-27	1,93	42,863	111/16				
UCFB209-28	1,89	44,45	13/4				
UCFB209	1,87	45	–				
UCFB210-29	2,25	46,038	113/16				
UCFB210-30	2,2	47,625	17/8				
UCFB210-31	2,16	49,213	115/16				
UCFB210	2,13	50	–				
UCFB210-32	2,11	50,8	2				

								Housing	Radial insert ball bearing
A	A ₁	A ₂	N	N ₁	N ₂	B	U		
24	13	13,5	9,5	32	27	31	31,8	FB204	UC201
									UC201-08
									UC202-09
									UC202
									UC202-10
									UC203
									UC203-11
									UC204-12
UC204									
26	13	15	9,5	34	27	34,1	34,8	FB205	UC205-13
									UC205-14
									UC205-15
									UC205
									UC205-16
29	13	17	9,5	40	29	38,1	39,2	FB206	UC206-17
									UC206-18
									UC206
									UC206-19
									UC206-20
33	15	19	9,5	46	32	42,9	44,4	FB207	UC207-20
									UC207-21
									UC207-22
									UC207
									UC207-23
34	16	20	11,1	50	41	49,2	50,2	FB208	UC208-24
									UC208-25
									UC208
34	18	20	11,1	54	43	49,2	50,2	FB209	UC209-26
									UC209-27
									UC209-28
									UC209
35	18	20	11,1	58	46	51,6	52,6	FB210	UC210-29
									UC210-30
									UC210-31
									UC210
									UC210-32

Four-bolt flanged housing units

Square version
With grub screws
in inner ring

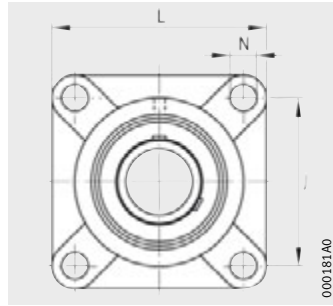

UCF

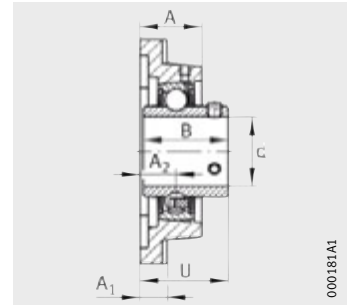

UCF

Dimension table · Dimensions in mm and inch

Designation	Mass m ≈kg	Dimensions		J	L	A	A ₁	A ₂	N	B	U	Housing	Radial insert ball bearing
		d											
		mm	inch										
UCF201	0,62	12	–	64	86	25,5	12	15	12	31	33,3	F204	UC201
UCF201-08	0,62	12,7	1/2										UC201-08
UCF202-09	0,61	14,288	9/16										UC202-09
UCF202	0,6	15	–										UC202
UCF202-10	0,6	15,875	5/8										UC202-10
UCF203	0,59	17	–										UC203
UCF203-11	0,59	17,463	11/16										UC203-11
UCF204-12	0,58	19,05	3/4										UC204-12
UCF204	0,57	20	–										UC204
UCF205-13	0,89	20,638	13/16										70
UCF205-14	0,87	22,225	7/8	UC205-14									
UCF205-15	0,86	23,813	15/16	UC205-15									
UCF205	0,85	25	–	UC205									
UCF205-16	0,84	25,4	1	UC205-16									
UCF206-17	1,15	26,988	1 1/16	83	108	31	14	18	12	38,1	40,2	F206	
UCF206-18	1,13	28,575	1 1/8										UC206-18
UCF206	1,11	30	–										UC206
UCF206-19	1,11	30,163	1 3/16										UC206-19
UCF206-20	1,09	31,75	1 1/4										UC206-20
UCF207-20	1,55	31,75	1 1/4										92
UCF207-21	1,53	33,338	1 5/16	UC207-21									
UCF207-22	1,5	34,925	1 3/8	UC207-22									
UCF207	1,5	35	–	UC207									
UCF207-23	1,47	36,513	1 7/16	UC207-23									
UCF208-24	1,95	38,1	1 1/2	102	130	36	16	21	16	49,2	51,2	F208	
UCF208-25	1,92	39,688	1 9/16										UC208-25
UCF208	1,91	40	–										UC208
UCF209-26	2,4	41,275	1 5/8	105	137	38	18	22	16	49,2	52,2	F209	UC209-26
UCF209-27	2,36	42,863	1 11/16										UC209-27
UCF209-28	2,32	44,45	1 3/4										UC209-28
UCF209	2,3	45	–										UC209
UCF210-29	2,67	46,038	1 13/16										111
UCF210-30	2,63	47,625	1 7/8	UC210-30									
UCF210-31	2,58	49,213	1 15/16	UC210-31									
UCF210	2,56	50	–	UC210									
UCF210-32	2,53	50,8	2	UC210-32									

Four-bolt flanged housing units

Square version
With grub screws
in inner ring

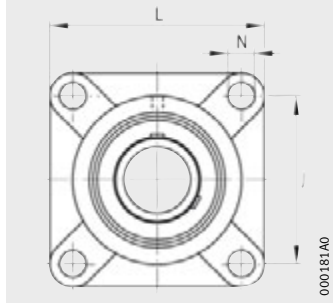

UCF

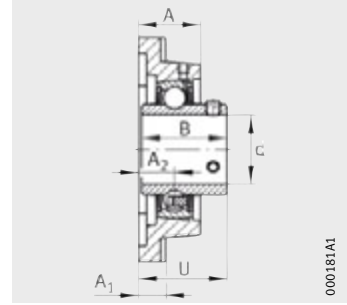

UCF

Dimension table (continued) · Dimensions in mm and *inch*

Designation	Mass m ≈kg	Dimensions										Housing	Radial insert ball bearing
		d		J	L	A	A ₁	A ₂	N	B	U		
		mm	<i>inch</i>										
UCF211-32	3,46	50,8	2	130	163	43	20	25	19	55,6	58,4	F211	UC211-32
UCF211-33	3,4	52,388	2 ¹ / ₁₆										UC211-33
UCF211-34	3,35	53,975	2 ¹ / ₁₆										UC211-34
UCF211	3,31	55	–										UC211
UCF211-35	3,29	55,563	2 ³ / ₁₆	143	175	48	20	29	19	65,1	68,7	F212	UC211-35
UCF212-36	4,38	57,15	2 ¹ / ₄										UC212-36
UCF212-37	4,31	58,738	2 ⁵ / ₁₆										UC212-37
UCF212	4,25	60	–										UC212
UCF212-38	4,23	60,325	2 ³ / ₈										UC212-38
UCF212-39	4,15	61,913	2 ⁷ / ₁₆	UC212-39									
UCF213-40	5	63,5	2 ¹ / ₂	149	187	50	20	30	19	65,1	69,7	F213	UC213-40
UCF213	4,91	65	–										UC213
UCF213-41	4,9	65,088	2 ⁹ / ₁₆										UC213-41
UCF214-42	6,19	66,675	2 ⁵ / ₈	152	193	54	24	31	19	74,6	75,4	F214	UC214-42
UCF214-43	6,09	68,263	2 ¹¹ / ₁₆										UC214-43
UCF214-44	5,99	69,85	2 ³ / ₁₆										UC214-44
UCF214	5,99	70	–										UC214
UCF215-45	6,89	71,438	2 ¹ / ₁₆	159	200	56	24	34	19	77,8	78,5	F215	UC215-45
UCF215-46	6,77	73,025	2 ⁷ / ₁₆										UC215-46
UCF215-47	6,67	74,613	2 ¹⁵ / ₁₆										UC215-47
UCF215	6,64	75	–										UC215
UCF215-48	6,58	76,2	3	UC215-48									
UCF216-49	7,57	77,788	3 ¹ / ₁₆	165	208	58	24	34	23	82,6	83,3	F216	UC216-49
UCF216-50	7,45	79,375	3 ¹ / ₈										UC216-50
UCF216	7,4	80	–										UC216
UCF216-51	7,32	80,963	3 ³ / ₁₆										UC216-51
UCF217-52	9,45	82,55	3 ¹ / ₄	175	220	63	26	36	23	85,7	87,6	F217	UC217-52
UCF217-53	9,29	84,138	3 ⁵ / ₁₆										UC217-53
UCF217	9,21	85	–										UC217
UCF217-55	8,98	87,313	3 ⁷ / ₁₆										UC217-55
UCF218-56	10,77	88,9	3 ¹ / ₂	187	235	68	26	40	23	96	96,3	F218	UC218-56
UCF218	10,66	90	–										UC218

Four-bolt flanged housing units

Square version
With adapter sleeve

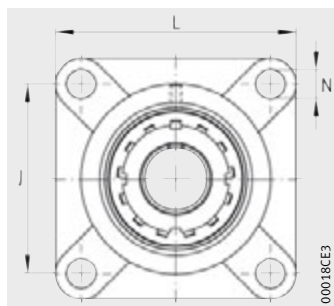

UKF

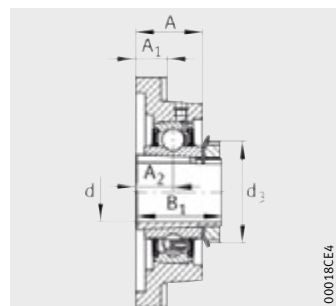

UKF

Dimension table - Dimensions in mm

Designation	Mass m ≈kg	Dimensions									Housing	Radial insert ball bearing
		d	J	L	A	A ₁	A ₂	N	B ₁	d ₃ max.		
UKF205	0,9	20	70	95	27	14	16	12	35	38	F205	UK205
UKF206	1,18	25	83	108	31	14	18	12	38	45	F206	UK206
UKF207	1,58	30	92	117	34	16	19	14	43	52	F207	UK207
UKF208	1,99	35	102	130	36	16	21	16	46	58	F208	UK208
UKF209	2,44	40	105	137	38	18	22	16	50	65	F209	UK209
UKF210	2,73	45	111	143	40	18	22	16	55	70	F210	UK210
UKF211	3,48	50	130	163	43	20	25	19	59	75	F211	UK211
UKF212	4,34	55	143	175	48	20	29	19	62	80	F212	UK212
UKF213	5,06	60	149	187	50	20	30	19	65	85	F213	UK213
UKF215	7,09	65	159	200	56	24	34	19	73	98	F215	UK215
UKF216	7,9	70	165	208	58	24	34	23	78	105	F216	UK216
UKF217	9,46	75	175	220	63	26	36	23	82	110	F217	UK217
UKF218	11,17	80	187	235	68	26	40	23	86	120	F218	UK218

Four-bolt flanged housing units

Round version
With grub screws
in inner ring

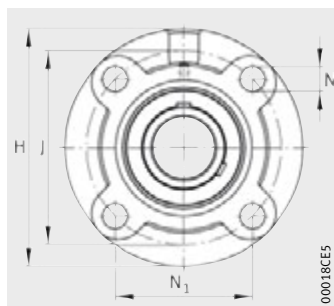

UCFC

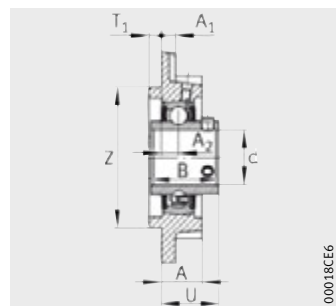

UCFC

Dimension table · Dimensions in mm and inch

Designation	Mass m ≈kg	Dimensions		H	J	N ₁
		d mm	inch			
UCFC201	0,77	12	–	100	78	55,1
UCFC201-08	0,77	12,7	1/2			
UCFC202-09	0,76	14,288	9/16			
UCFC202	0,76	15	–			
UCFC202-10	0,75	15,875	5/8			
UCFC203	0,74	17	–			
UCFC203-11	0,74	17,463	11/16			
UCFC204-12	0,73	19,05	3/4			
UCFC204	0,72	20	–	115	90	63,6
UCFC205-13	0,98	20,638	13/16			
UCFC205-14	0,97	22,225	7/8			
UCFC205-15	0,95	23,813	15/16			
UCFC205	0,94	25	–			
UCFC205-16	0,94	25,4	1	125	100	70,7
UCFC206-17	1,29	26,988	11/16			
UCFC206-18	1,27	28,575	11/8			
UCFC206	1,25	30	–			
UCFC206-19	1,25	30,163	13/16	135	110	77,8
UCFC206-20	1,23	31,75	11/4			
UCFC207-20	1,76	31,75	11/4			
UCFC207-21	1,73	33,338	15/16			
UCFC207-22	1,7	34,925	13/8			
UCFC207	1,7	35	–	145	120	84,8
UCFC207-23	1,67	36,513	17/16			
UCFC208-24	2,08	38,1	11/2			
UCFC208-25	2,04	39,688	19/16	160	132	93,3
UCFC208	2,03	40	–			
UCFC209-26	2,78	41,275	15/8			
UCFC209-27	2,74	42,863	111/16			
UCFC209-28	2,7	44,45	13/4			
UCFC209	2,69	45	–	165	138	97,6
UCFC210-29	3,08	46,038	113/16			
UCFC210-30	3,03	47,625	17/8			
UCFC210-31	2,98	49,213	115/16			
UCFC210	2,96	50	–			
UCFC210-32	2,94	50,8	2			

								Housing	Radial insert ball bearing
A	A ₁	A ₂	N	Z h8	T ₁	B	U		
20,5	8	10	12	62	5	31	28,3	FC204	UC201
									UC201-08
									UC202-09
									UC202
									UC202-10
									UC203
									UC203-11
									UC204-12
UC204									
21	7	10	12	70	6	34,1	29,8	FC205	UC205-13
									UC205-14
									UC205-15
									UC205
									UC205-16
23	8	10	12	80	8	38,1	32,2	FC206	UC206-17
									UC206-18
									UC206
									UC206-19
									UC206-20
26	9	11	14	90	8	42,9	36,4	FC207	UC207-20
									UC207-21
									UC207-22
									UC207
									UC207-23
26	9	11	14	100	10	49,2	41,2	FC208	UC208-24
									UC208-25
									UC208
26	14	10	16	105	12	49,2	40,2	FC209	UC209-26
									UC209-27
									UC209-28
									UC209
28	14	10	16	110	12	51,6	42,6	FC210	UC210-29
									UC210-30
									UC210-31
									UC210
									UC210-32

Four-bolt flanged housing units

Round version
With grub screws
in inner ring

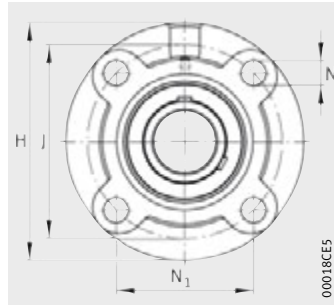

UCFC

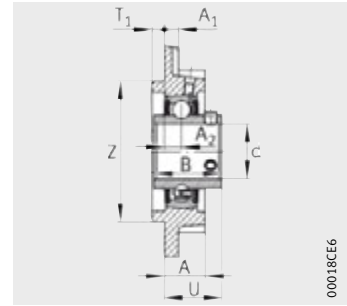

UCFC

Dimension table (continued) - Dimensions in mm and *inch*

Designation	Mass m ≈kg	Dimensions		H	J	N ₁
		d mm	<i>inch</i>			
UCFC211-32	4,13	50,8	2	185	150	106,1
UCFC211-33	4,07	52,388	2 ¹ / ₁₆			
UCFC211-34	4,02	53,975	2 ¹ / ₈			
UCFC211	3,98	55	–			
UCFC211-35	3,96	55,563	2 ³ / ₁₆	195	160	113,1
UCFC212-36	5	57,15	2 ¹ / ₄			
UCFC212-37	4,92	58,738	2 ⁵ / ₁₆			
UCFC212	4,86	60	–			
UCFC212-38	4,85	60,325	2 ³ / ₈	205	170	120,2
UCFC212-39	4,77	61,913	2 ⁷ / ₁₆			
UCFC213-40	5,54	63,5	2 ¹ / ₁₂			
UCFC213	5,45	65	–			
UCFC213-41	5,44	65,088	2 ⁹ / ₁₆	215	177	125,15
UCFC214-42	6,84	66,675	2 ⁵ / ₈			
UCFC214-43	6,74	68,263	2 ¹¹ / ₁₆			
UCFC214-44	6,64	69,85	2 ³ / ₄			
UCFC214	6,64	70	–	220	184	130,1
UCFC215-45	7,48	71,438	2 ¹³ / ₁₆			
UCFC215-46	7,36	73,025	2 ⁷ / ₈			
UCFC215-47	7,26	74,613	2 ¹⁵ / ₁₆			
UCFC215	7,23	75	–	240	200	141,4
UCFC215-48	7,15	76,2	3			
UCFC216-49	8,98	77,788	2 ¹ / ₁₆			
UCFC216-50	8,86	79,375	2 ¹ / ₈			
UCFC216	8,81	80	–	250	208	147,1
UCFC216-51	8,73	80,963	2 ³ / ₁₆			
UCFC217-52	10,8	82,55	2 ¹ / ₄			
UCFC217-53	10,64	84,138	2 ⁵ / ₁₆			
UCFC217	10,56	85	–	265	220	155,55
UCFC217-55	10,33	87,313	2 ⁷ / ₁₆			
UCFC218-56	12,29	88,9	2 ¹ / ₂			
UCFC218	12,18	90	–			

								Housing	Radial insert ball bearing
A	A ₁	A ₂	N	Z h8	T ₁	B	U		
31	15	13	19	125	12	55,6	46,4	FC211	UC211-32
									UC211-33
									UC211-34
									UC211
									UC211-35
36	15	17	19	135	12	65,1	56,7	FC212	UC212-36
									UC212-37
									UC212
									UC212-38
									UC212-39
36	15	16	19	145	14	65,1	55,7	FC213	UC213-40
									UC213
									UC213-41
40	18	17	19	150	14	74,6	61,4	FC214	UC214-42
									UC214-43
									UC214-44
									UC214
40	18	18	19	160	16	77,8	62,5	FC215	UC215-45
									UC215-46
									UC215-47
									UC215
									UC215-48
42	18	18	23	170	16	82,6	67,3	FC216	UC216-49
									UC216-50
									UC216
									UC216-51
45	20	18	23	180	18	85,7	69,6	FC217	UC217-52
									UC217-53
									UC217
									UC217-55
50	20	22	23	190	18	96	78,3	FC218	UC218-56
									UC218

Four-bolt flanged housing units

Round version
With adapter sleeve

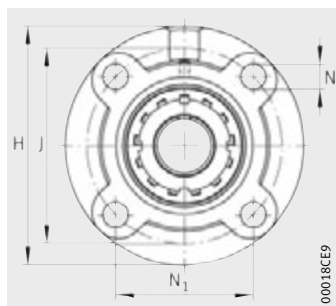

UKFC

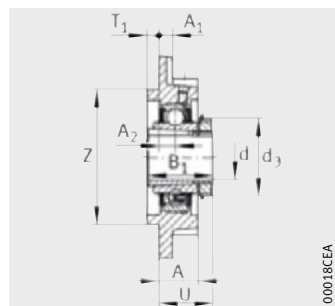

UKFC

Dimension table · Dimensions in mm

Designation	Mass m ≈ kg	Dimensions			
		d	H	J	N ₁
UKFC205	0,99	20	115	90	63,6
UKFC206	1,31	25	125	100	70,7
UKFC207	1,78	30	135	110	77,8
UKFC208	2,12	35	145	120	84,8
UKFC209	2,82	40	160	132	93,3
UKFC210	3,14	45	165	138	97,6
UKFC211	4,15	50	185	150	106,1
UKFC212	4,95	55	195	160	113,1
UKFC213	5,6	60	205	170	120,2
UKFC215	7,68	65	220	184	130,1
UKFC216	9,31	70	240	200	141,4
UKFC217	10,81	75	250	208	147,1
UKFC218	12,69	80	265	220	155,55

								Housing	Radial insert ball bearing
A	A ₁	A ₂	N	Z	T ₁	B ₁	d ₃ max.		
21	7	10	12	70	6	35	38	FC205	UK205
23	8	10	12	80	8	38	45	FC206	UK206
26	9	11	14	90	8	43	52	FC207	UK207
26	9	11	14	100	10	46	58	FC208	UK208
26	14	10	16	105	12	50	65	FC209	UK209
28	14	10	16	110	12	55	70	FC210	UK210
31	15	13	19	125	12	59	75	FC211	UK211
36	15	17	19	135	12	62	80	FC212	UK212
36	15	16	19	145	14	65	85	FC213	UK213
40	18	18	19	160	16	73	98	FC215	UK215
42	18	18	23	170	16	78	105	FC216	UK216
45	20	18	23	180	18	82	110	FC217	UK217
50	20	22	23	190	18	86	120	FC218	UK218

Take-up housing units

For linear motion
With grub screws
in inner ring

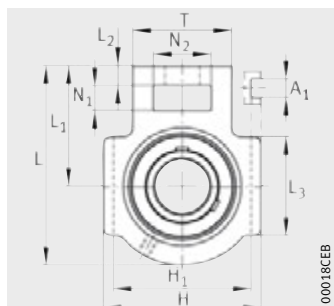

UCT

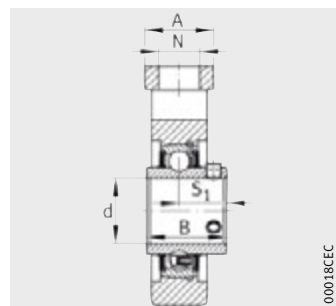

UCT

Dimension table · Dimensions in mm and *inch*

Designation	Mass m ≈kg	Dimensions		L	L ₁	L ₂	L ₃
		d					
		mm	inch				
UCT201	0,77	12	–	94	61	10	51
UCT201-08	0,77	12,7	1/2				
UCT202-09	0,76	14,288	9/16				
UCT202	0,75	15	–				
UCT202-10	0,75	15,875	5/8				
UCT203	0,74	17	–				
UCT203-11	0,74	17,463	11/16				
UCT204-12	0,73	19,05	3/4				
UCT204	0,72	20	–	97	62	10	51
UCT205-13	0,84	20,638	13/16				
UCT205-14	0,83	22,225	7/8				
UCT205-15	0,81	23,813	15/16				
UCT205	0,8	25	–				
UCT205-16	0,8	25,4	1	113	70	10	57
UCT206-17	1,27	26,988	1 1/16				
UCT206-18	1,25	28,575	1 1/8				
UCT206	1,23	30	–				
UCT206-19	1,23	30,163	1 3/16	129	78	13	64
UCT206-20	1,2	31,75	1 1/4				
UCT207-20	1,64	31,75	1 1/4				
UCT207-21	1,61	33,338	1 5/16	144	88	16	83
UCT207-22	1,58	34,925	1 3/8				
UCT207	1,58	35	–				
UCT207-23	1,55	36,513	1 7/16	144	87	16	83
UCT208-24	2,36	38,1	1 1/2				
UCT208-25	2,33	39,688	1 9/16				
UCT208	2,32	40	–				
UCT209-26	2,46	41,275	1 5/8	149	90	16	86
UCT209-27	2,42	42,863	1 11/16				
UCT209-28	2,38	44,45	1 3/4				
UCT209	2,37	45	–				
UCT210-29	2,64	46,038	1 13/16	149	90	16	86
UCT210-30	2,59	47,625	1 7/8				
UCT210-31	2,54	49,213	1 15/16				
UCT210	2,52	50	–				
UCT210-32	2,5	50,8	2				

										Housing	Radial insert ball bearing
N	N ₁	N ₂	A	H	H ₁	A ₁	B	S ₁	T		
19	16	32	32	89	76	12	31	18,3	51	T204	UC201
											UC201-08
											UC202-09
											UC202
											UC202-10
											UC203
											UC203-11
											UC204-12
UC204											
19	16	32	32	89	76	12	34,1	19,8	51	T205	UC205-13
											UC205-14
											UC205-15
											UC205
											UC205-16
22	16	37	37	102	89	12	38,1	22,2	56	T206	UC206-17
											UC206-18
											UC206
											UC206-19
											UC206-20
22	16	37	37	102	89	12	42,9	25,4	64	T207	UC207-20
											UC207-21
											UC207-22
											UC207
											UC207-23
29	19	49	49	114	102	16	49,2	30,2	83	T208	UC208-24
											UC208-25
											UC208
29	19	49	49	117	102	16	49,2	30,2	83	T209	UC209-26
											UC209-27
											UC209-28
											UC209
29	19	49	49	117	102	16	51,6	32,6	83	T210	UC210-29
											UC210-30
											UC210-31
											UC210
											UC210-32

Take-up housing units

For linear motion
With grub screws
in inner ring

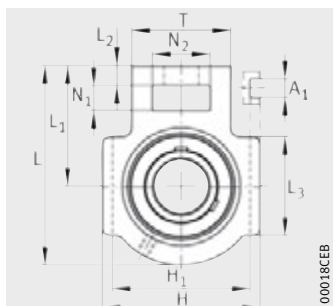

UCT

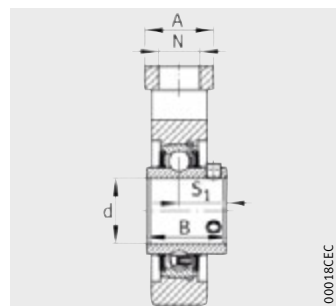

UCT

Dimension table (continued) - Dimensions in mm and *inch*

Designation	Mass m ≈ kg	Dimensions		L	L ₁	L ₂	L ₃
		d					
		mm	<i>inch</i>				
UCT211-32	3,98	50,8	2	171	106	19	95
UCT211-33	3,93	52,388	2 ¹ / ₁₆				
UCT211-34	3,87	53,975	2 ¹ / ₈				
UCT211	3,83	55	–				
UCT211-35	3,81	55,563	2 ³ / ₁₆	194	119	19	102
UCT212-36	4,84	57,15	2 ¹ / ₄				
UCT212-37	4,77	58,738	2 ⁵ / ₁₆				
UCT212	4,71	60	–				
UCT212-38	4,69	60,325	2 ³ / ₈	224	137	21	121
UCT212-39	4,61	61,913	2 ⁷ / ₁₆				
UCT213-40	6,71	63,5	2 ¹ / ₂				
UCT213	6,62	65	–				
UCT213-41	6,61	65,088	2 ⁹ / ₁₆	224	137	21	121
UCT214-42	6,99	66,675	2 ⁵ / ₈				
UCT214-43	6,89	68,263	2 ¹¹ / ₁₆				
UCT214-44	6,79	69,85	2 ³ / ₄				
UCT214	6,79	70	–	232	140	21	121
UCT215-45	7,45	71,438	2 ¹³ / ₁₆				
UCT215-46	7,33	73,025	2 ⁷ / ₈				
UCT215-47	7,23	74,613	2 ¹⁵ / ₁₆				
UC215	7,2	75	–	235	140	21	121
UCT215-48	7,12	76,2	3				
UCT216-49	8,27	77,788	3 ¹ / ₁₆				
UCT216-50	8,15	79,375	3 ¹ / ₈				
UCT216	8,1	80	–	260	162	29	157
UCT216-51	8,02	80,963	3 ³ / ₁₆				
UCT217-52	11,1	82,55	3 ¹ / ₄				
UCT217-53	10,94	84,138	3 ⁵ / ₁₆				
UCT217	10,86	85	–	275	170	30	140
UCT217-55	10,63	87,313	3 ⁷ / ₁₆				
UCT218-56	12,38	88,9	3 ¹ / ₂				
UCT218	12,27	90	–				

										Housing	Radial insert ball bearing
N	N ₁	N ₂	A	H	H ₁	A ₁	B	S ₁	T		
35	25	64	64	146	130	22	55,6	33,4	102	T211	UC211-32
											UC211-33
											UC211-34
											UC211
											UC211-35
35	32	64	64	146	130	22	65,1	39,7	102	T212	UC212-36
											UC212-37
											UC212
											UC212-38
											UC212-39
41	32	70	70	167	151	26	65,1	39,7	111	T213	UC213-40
											UC213
											UC213-41
41	32	70	70	167	151	26	74,6	44,4	111	T214	UC214-42
											UC214-43
											UC214-44
											UC214
41	32	70	70	167	151	26	77,8	44,5	111	T215	UC215-45
											UC215-46
											UC215-47
											UC215
41	32	70	70	184	165	26	82,6	49,3	111	T216	UC216-49
											UC216-50
											UC216
											UC216-51
48	38	73	73	198	173	30	85,7	51,6	124	T217	UC217-52
											UC217-53
											UC217
											UC217-55
47	40	80	80	215	190	28	96	56,3	130	T218	UC218-56
											UC218

Take-up housing units

For linear motion
With adapter sleeve

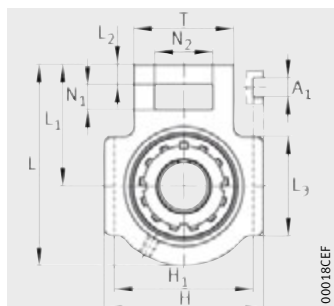

UKT

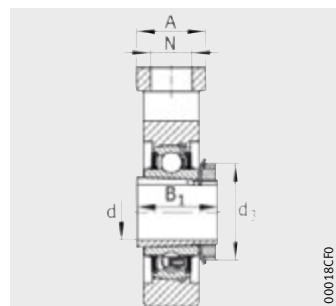

UKT

Dimension table · Dimensions in mm

Designation	Mass m ≈kg	Dimensions				
		d	L	L ₁	L ₂	L ₃
UKT205	0,85	20	97	62	10	51
UKT206	1,29	25	113	70	10	57
UKT207	1,66	30	129	78	13	64
UKT208	2,4	35	144	88	16	83
UKT209	2,5	40	144	87	16	83
UKT210	2,7	45	149	90	16	86
UKT211	4	50	171	106	19	95
UKT212	4,79	55	194	119	19	102
UKT213	6,77	60	224	137	21	121
UKT215	7,65	65	232	140	21	121
UKT216	8,6	70	235	140	21	121
UKT217	11,11	75	260	162	29	157
UKT218	12,78	80	275	170	30	140

										Housing	Radial insert ball bearing
N	N ₁	N ₂	A	H	H ₁	A ₁	B ₁	d ₃ max.	T		
19	16	32	32	89	76	12	35	38	51	T205	UK205
22	16	37	37	102	89	12	38	45	56	T206	UK206
22	16	37	37	102	89	12	43	52	64	T207	UK207
29	19	49	49	114	102	16	46	58	83	T208	UK208
29	19	49	49	117	102	16	50	65	83	T209	UK209
29	19	49	49	117	102	16	55	70	83	T210	UK210
35	25	64	64	146	130	22	59	75	102	T211	UK211
35	32	64	64	146	130	22	62	80	102	T212	UK212
41	32	70	70	167	151	26	65	85	111	T213	UK213
41	32	70	70	167	151	26	73	98	111	T215	UK215
41	32	70	70	184	165	26	78	105	111	T216	UK216
48	38	73	73	198	173	30	82	110	124	T217	UK217
47	40	80	80	215	190	28	86	120	130	T218	UK218

Take-up housing units

For swivel motion
With grub screws
in inner ring

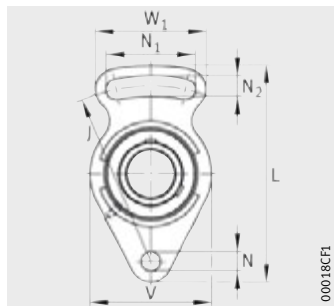

UCFA

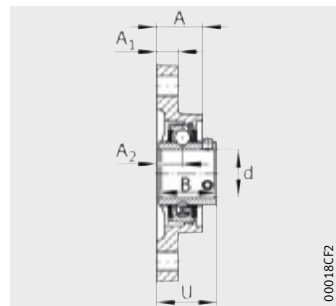

UCFA

Dimension table · Dimensions in mm and *inch*

Designation	Mass m ≈kg	Dimensions		L	J	A	A ₁	A ₂
		d						
		mm	<i>inch</i>					
UCFA201	0,45	12	–	98	78	25,5	12	15
UCFA201-08	0,45	12,7	1/2					
UCFB202-09	0,44	14,288	9/16					
UCFA202	0,44	15	–					
UCFA202-10	0,43	15,875	5/8					
UCFA203	0,43	17	–					
UCFA203-11	0,42	17,463	11/16					
UCFA204-12	0,41	19,05	3/4					
UCFA204	0,41	20	–	125	98	27	14	16
UCFA205-13	0,67	20,638	13/16					
UCFA205-14	0,66	22,225	7/8					
UCFA205-15	0,64	23,813	15/16					
UCFA205	0,63	25	–					
UCFA205-16	0,62	25,4	1	144	117	31	14	18
UCFA206-17	0,94	26,988	1 1/16					
UCFA206-18	0,92	28,575	1 1/8					
UCFA206	0,9	30	–					
UCFA206-19	0,9	30,163	1 3/16					
UCFA206-20	0,88	31,75	1 1/4					

							Housing	Radial insert ball bearing
N	N ₁	N ₂	V	W ₁	B	U		
10	40	10	60	50	31	33,3	FA204	UC201
								UC201-08
								UC202-09
								UC202
								UC202-10
								UC203
								UC203-11
								UC204-12
12	51	12	68	66	34,1	35,8	FA205	UC204
								UC205-13
								UC205-14
								UC205-15
								UC205
12	58	12	80	72	38,1	40,2	FA206	UC205-16
								UC206-17
								UC206-18
								UC206
								UC206-19
								UC206-20

Take-up housing units

For swivel motion
With grub screws
in inner ring

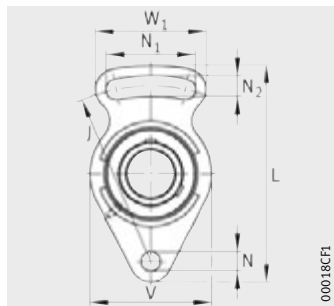

UCFA

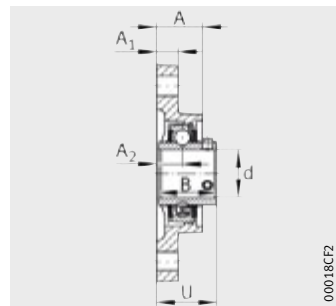

UCFA

Dimension table (continued) - Dimensions in mm and *inch*

Designation	Mass m ≈kg	Dimensions		L	J	A	A ₁	A ₂
		d						
		mm	<i>inch</i>					
UCFA207-20	1,29	31,75	<i>1¹/₄</i>	161	130	34	16	19
UCFA207-21	1,26	33,338	<i>1⁵/₁₆</i>					
UCFA207-22	1,24	34,925	<i>1³/₈</i>					
UCFA207	1,23	35	–					
UCFA207-23	1,21	36,513	<i>1⁷/₁₆</i>					
UCFA208-24	1,58	38,1	<i>1¹/₂</i>	175	144	36	16	21
UCFA208-25	1,54	39,688	<i>1⁹/₁₆</i>					
UCFA208	1,53	40	–					
UCFA209-26	1,99	41,275	<i>1⁵/₈</i>	181	148	38	18	22
UCFA209-27	1,95	42,863	<i>1¹¹/₁₆</i>					
UCFA209-28	1,91	44,45	<i>1³/₄</i>					
UCFA209	1,9	45	–					
UCFA210-29	2,2	46,038	<i>1¹³/₁₆</i>	190	157	37,5	18	22
UCFA210-30	2,16	47,625	<i>1⁷/₈</i>					
UCFA210-31	2,11	49,213	<i>1¹⁵/₁₆</i>					
UCFA210	2,08	50	–					
UCFA210-32	2,06	50,8	<i>2</i>					
UCFA211-32	3,1	50,8	<i>2</i>	219	184	43	20	25
UCFA211-33	3,05	52,388	<i>2¹/₁₆</i>					
UCFA211-34	2,99	53,975	<i>2¹/₈</i>					
UCFA211	2,95	55	–					
UCFA211-35	2,93	55,563	<i>2³/₁₆</i>					

							Housing	Radial insert ball bearing
N	N ₁	N ₂	V	W ₁	B	U		
14	66	14	90	82	42,9	44,4	FA207	UC207-20
								UC207-21
								UC207-22
								UC207
								UC207-23
14	71	14	100	87	49,2	51,2	FA208	UC208-24
								UC208-25
								UC208
16	72	16	108	90	49,2	52,2	FA209	UC209-26
								UC209-27
								UC209-28
								UC209
16	76	16	115	94	51,6	54,6	FA210	UC210-29
								UC210-30
								UC210-31
								UC210
								UC210-32
16	86	16	130	104	55,6	58,4	FA211	UC211-32
								UC211-33
								UC211-34
								UC211
								UC211-35

**Schaeffler Technologies
AG & Co. KG**

Georg-Schäfer-Straße 30
97421 Schweinfurt
Germany
Internet www.fag.com
E-mail FAGinfo@schaeffler.com

In Germany:

Phone 0180 5003872
Fax 0180 5003873

From other countries:

Phone +49 9721 91-0
Fax +49 9721 91-3435

Every care has been taken to ensure the correctness of the information contained in this publication but no liability can be accepted for any errors or omissions. We reserve the right to make technical changes.

© Schaeffler Technologies AG & Co. KG
Issued: 2012, June

This publication or parts thereof may not be reproduced without our permission.
TPI 219 GB-D